



Signature Series™

L-858 Taxiway & Runway Signs

Uses power supply 44A6225 and 44A6225/4

Document No. 96A0286

Issued: November 16, 2001

Rev. AG: June 07, 2009

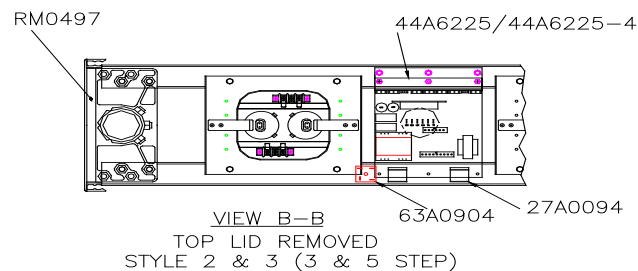

ETL Certified to FAA Specification
AC 150/5345-44

ADB

P.O. Box 30829
977 Gahanna Parkway
Columbus, OH 43230

Tel: (614) 861-1304
Fax: (614) 864-2069

Copyright © 2008 by ADB Airfield Solutions All rights reserved.

Record of Changes

Page	Rev	Description	EC No.	Checked	Approved	Date
2-11, 2-12, 2-13, 7-3, 7-4, 7-5, 7-8, 7-9	X	Revised sign power, VA load in Tables 2-15, 2-17, & 2-19 correct transformer info and descriptions	01533	WT	JR	2/8/06
vii, viii, Tables 2-4, 2-15, 2-16 2-17, 2-18, 2-19, 2-1, 2-22, 2-3, 2-24, pg 7-3	Y	Revised table of contents, warranty, power factor/VA load tables, CCR sizing tables, revised parts list	01548	WT	WT	2/23/06
3-3	Z	Revised Table 3-3 1-1/4 fitting was ¼ fitting	01574	WT	WT	3/24/06
Fig 6-6 Fig 7-1, Fig 7-4, pg 6-4, 7-3, 7-4	AA	Added new fluorescent ballast mounting bracket and correct part number errors in parts list, Revised Wiring Schematic.	01593	BB/WT	WT	6/23/06
Figs 7-1 & 8-1 thru 8-6. Tables 2-21, 2-15, 2-17 & 2-19. Pgs 5-6 thru 5-10, 7-3, & 7-8.	AB	Updated Fluorescent Power Supply to 44A6631. Updated FL Sign isolation transformers, VA, & PF. Updated isolation transformer, VA, & PF on Standard VA 5-step, 6 lamp sign. Corrected p/n for Optical Assembly. Added pg 5-6 thru 5-10.	1770	JJR	JJR	07/11/07
Pages 2-12 and 2-13 5-3	AC	Updated sign isolation transformers. Added troubleshooting information to increase XF size if sign lamps won't turn on.	1857	EPD	EPD	12/10/07
7-3, 7-4, 7-5, 7-9	AD	Updated spares (Section 7)	1907	JC	JC	3/18/08
8-5	AE	Updated bridge circuit connections	2058	BE	ER	8/27/08
Section 7	AF	Updated Order Codes and parts		BE	ER	01/08/09
Sections 6-7	AG	Updated Repair and Maintenance sections for new power supply and ballasts.	2339	BE	ER	06/07/09

Table of Contents

Record of Changes	ii
Table of Contents	iv
Warranties	viii

Safety

Section 1 Safety.....	1-1
1. Introduction	1-1
2. Safety Symbols	1-2
3. Qualified Personnel	1-2
4. Intended Use	1-3
5. Installation	1-3
6. Operation	1-4
7. Action in the Event of a System or Component Malfunction.....	1-5
8. Maintenance and Repair	1-5

Description

Section 2 Description.....	2-1
1. Introduction	2-1
2. Optional Equipment	2-2
Optional Lamps-Out Indicator	2-2
Optional On/Off Switch	2-3
3. L-858 Signs: Required Equipment.....	2-4
4. Specifications	2-4
Rated Lamp Life	2-4
Construction.....	2-4
Visibility.....	2-4
Style.....	2-5
Class.....	2-5
Conditions for Continuous Outdoor Use	2-5
Sign Classification.....	2-6
Number of Lamps Per Module	2-6
Modular Combination Lengths	2-6
Frangibility	2-6
Dimensions	2-7
Sign Power Factor and Total VA Load	2-11
Sign Weight.....	2-16

Installation	Section 3 Installation 3-1
	1. Introduction 3-1
	2. Unpacking 3-1
	3. Cordset Installation..... 3-1
	Cordset Installation Reference Numbers 3-1
	Cordset and Extension Cords..... 3-6
	4. Installation 3-7
	General Guidelines 3-7
	Overall Mounting Height..... 3-7
	Sign Orientation 3-7
	Sign Installation on Concrete Pad 3-8
	Wiring 3-14
	Optional Tethers 3-15
	Optional L-830 Series Wiring 3-16
Maintenance	Section 4 Maintenance 4-1
	1. Introduction 4-1
	2. Maintenance Schedule 4-1
Troubleshooting	Section 5 Troubleshooting 5-1
	1. Introduction 5-1
	2. Troubleshooting Procedures 5-1
	3. Jumper Settings..... 5-4
	4. Lamp Current Adjustment Procedure..... 5-5
	5. Active Ballast Assembly LEDs..... 5-10
	6. Active Ballast Assembly Connections 5-11
Repair	Section 6 Repair 6-1
	1. Introduction 6-1
	2. Lamp Replacement 6-11
	3. Active Ballast Assembly Replacement 6-3
Parts	Section 7 Parts..... 7-7
	1. Introduction 7-7
	2. Using the Illustrated Parts List 7-7
	3. L-858 Sign Ordering Code 7-1
	4. L-858 Sign Parts List..... 7-2
	5. L-858 Sign Legend Panel Assembly Parts List 7-5
	6. L-858 Sign Mirror Parts List 7-6
	7. Optional Lamps-Out Indicator Kit 7-6
	8. Optional On/Off Switch 7-6
	9. Recommended Spare Parts..... 7-7
Wiring Schematics	Section 8 Wiring Schematics 8-1
	1. Introduction 8-1
	2. Wiring Schematics 8-1

List of Figures

Figure 2-1 L-858 Taxiway and Runway Sign (1-Module).....	2-1
Figure 2-2 Optional On/Off Switch	2-3
Figure 2-3 L-858 Sign Dimensions (Sizes 1, 2, 3, and 5/One-Module)	2-7
Figure 2-4 L-858 Sign Dimensions (Sizes 1, 2, 3/Two-Module)	2-8
Figure 2-5 L-858 Sign Dimensions (Sizes 1, 2, 3/Three-Module) L- 858 Sign Dimensions (Sizes 1, 2, 3/Three-Module)	2-8
Figure 2-6 L-858 Sign Dimensions (Sizes 1, 2, 3/Four-Module).....	2-9
Figure 2-7 L-858 Sign Dimensions (Size 4/One-Module).....	2-10
Figure 3-1 Cord set Location #1 (Non-typical).....	3-2
Figure 3-2 Cord set Location #2 (Non-typical).....	3-3
Figure 3-3 Cord set Location #3 (Standard)	3-4
Figure 3-4 Cord set Location #4 (Standard)	3-5
Figure 3-5 L-823 Cord set and Extension Cords.....	3-6
Figure 3-6 Mode 1 and 2 Frangible Couplings.....	3-9
Figure 3-7 Mode 3 Frangible Couplings.....	3-9
Figure 3-8 Sign Frangible Coupling	3-10
Figure 3-9 Lamps-Out Indicator Kit Assembly	3-12
Figure 3-10 Lamps-Out Indicator Wiring	3-13
Figure 3-11 Installing Optional Tether	3-15
Figure 3-12 Installing Optional L-830 Series Wiring	3-17
Figure 5-1 Active Ballast Assembly (Board C)	5-4
Figure 5-2-A Transformer Taps to change lamp current	5-7
Figure 5-3 Low VA (Active Ballast) Assembly - Main Board	5-10
Figure 6-1 Lamp Replacement (Shown with Backup Lamp)	6-1
Figure 6-2 Replacing Active Ballast Assembly -48W/MR 16 Lamps .	6-3
Figure 6-3 Lamp Bracket ¼-turn Screw	6-4
Figure 6-4 Lamp Bracket Removal	6-4
Figure 6-5 Lamp Socket	6-4
Figure 6-6 Ballast Mounting	6-5
Figure 6-7 DC Power Supply	6-5
Figure 6-8 Regular VA Transformer and CAP	6-6
Figure 7-1 L-858 Sign Module Assembly (Shown with Backup Lamps)	7-4
Figure 8-1 Style 5 Wiring Schematic – 48W/MR16 Lamps (Sizes 1, 3, 4, 5).....	8-1
Figure 8-2 Style 5 Wiring Schematic- 48W/MR16 Lamps (Size 2) ...	8-2
Figure 8-3 WIRING DIAGRAM, 3 STEP STANDARD VA	8-3
Figure 8-4 WIRING DIAGRAM, 5 STEP STANDARD VA	8-4
Figure 8-5 L-858 Wiring Schematic (Styles 2 and 3/All Sizes and All Modules -48W/MR16 Lamps)	8-5
Figure 8-6 L-858 Wiring Schematic (Styles 2 /All Sizes and All Modules -48W/MR16 Lamps)	8-6
Figure 8-7 L-858 Wiring Schematic (Styles 2 /All Sizes and All Modules -48W/MR16 Lamps)	8-7
Figure 8-8 Wiring for 1-8 Lamps.....	8-8

List of Tables

Table 2-1	L-858 Taxiway and Runway Signs.....	2-1
Table 2-2	Required Equipment Supplied	2-4
Table 2-3	Required Equipment Not Supplied.....	2-4
Table 2-4	Sign Style	2-5
Table 2-5	Sign Class	2-5
Table 2-6	Sign Classification.....	2-6
Table 2-7	Number of Lamps Per Module (Style 2 and 3).....	2-6
Table 2-8	Modular Combination Lengths.....	2-6
Table 2-9	L-858 Size 1 Sign Dimensions	2-9
Table 2-10	L-858 Size 2 Sign Dimensions	2-9
Table 2-11	L-858 Size 3 Sign Dimensions	2-10
Table 2-12	L-858 Size 5 Sign Dimensions	2-10
Table 2-13	L-858 Size 4 Sign Dimensions	2-11
Table 2-14	(1-step) Sign Power Factor and VA Load (Using 48 W/MR16 Lamps)	2-11
Table 2-15	5 (1-step) Sign Power Factor and VA Load (Using 18W fluorescent lamps).....	2-11
Table 2-16	Low VA Style 2 (3-Step) Sign Power Factor and VA Load (Using 48W/MR16 Lamps).....	2-12
Table 2-17	Style 2 (3-Step) Sign Power Factor and VA Load (Using 18W fluorescent lamps).....	2-12
Table 2-18	Style 3 (5-Step) Sign Power Factor and VA Load (Using 48 W/MR16 Lamps)	2-12
Table 2-19	3 (5-Step) Sign Power Factor and VA Load (Using 18W fluorescent lamps).....	2-13
Table 2-20	Standard VA Style 3 (3-Step) Sign Power Factor and VA Load (Using 48W/MR16 Lamps)	2-13
Table 2-21	VA Style 3 (5-Step) Sign Power Factor and VA Load (Using 48W/MR16 Lamps)	2-13
Table 2-22	3-Step Circuit CCR Selection Table	2-14
Table 2-23	-Step Circuit CCR Selection Table	2-15
Table 2-24	Sign Weight.....	2-16
Table 3-1	Cord set Location #1 Parts.....	3-2
Table 3-2	Cord set Location #2 Parts.....	3-3
Table 3-3	Flexible Conduit Connectors	3-3
Table 3-4	Cord set Location #3 Parts.....	3-4
Table 3-5	Cord set Location #4 Parts.....	3-5
Table 3-6	Cord set and Extension Cord Length.....	3-6
Table 3-7	Cord set and Extension Cord Parts	3-6
Table 3-8	Recommended Sign Distance from Pavement Edge	3-8
Table 3-9	L-830 Series Wiring Kit.....	3-17
Table 4-1	L-858 Taxiway and Runway Sign Maintenance	4-1
Table 5-1	Jumper Settings.....	5-4
Table 5-2	Low VA (Active Ballast) Assembly LEDs.....	5-10
Table 5-3	Active Ballast Assembly Connections	5-11

Warranties

WARRANTY FOR GOODS AND SERVICES: Seller warrants, to the extent to which any of the same may be applicable, that **(a)** on the date of shipment the goods are of the kind and quality described herein and are free of non-conformities in workmanship and material, **(b)** the engineering services performed by it will be performed in accordance with generally accepted professional standards, **(c)** any specialized tools, equipment and instruments for the use of which a charge is made to the Buyer shall be adequate for the work to be performed and **(d)** any replacement or other parts furnished by it or any work done by it on the Buyer's equipment or both shall be free of defects in workmanship and materials. This warranty does not apply to goods delivered by Seller but manufactured by others.

Buyer's exclusive remedy for any failure of the goods or services to conform to any of the applicable warranties shall be to have Seller re-perform services, repair or replace (at Seller's option) the nonconforming item and any affected part of the goods provided by Seller. Seller's obligation to re-perform services or to repair or replace goods shall be in effect for a period of one (1) year from initial operation of the goods or completion of Services but not more than eighteen (18) months from Seller's shipment of the goods. Seller shall correct any failure to conform to any of the applicable foregoing warranties of which it is notified in writing within that period of time specified.

Repaired and replacement parts and repair services shall be warranted for the remainder of the original period of notification set forth above, but in no event less than 12 months from repair or replacement. In the case of any other breach of the foregoing warranty, Seller shall furnish engineering services or specialized tools, equipment and instruments, to the same extent as on the original work. Buyer shall grant Seller access to the goods or services at all reasonable times in order for Seller to determine any nonconformity in the goods or services. It is understood and agreed that, unless otherwise agreed to in writing by Seller, Seller assumes no responsibility with respect to the suitability of the Buyer's equipment or any latent defects in the same. In no event shall Seller be responsible for providing working access to the defect, including the removal, disassembly, replacement or reinstallation of any equipment, materials or structures to the extent necessary to permit Seller to perform its warranty obligations, or transportation costs to and from the Seller factory or repair facility, or for damage to equipment components or parts resulting in whole or in part from improper maintenance or operation or from their deteriorated condition. Seller shall have the right of disposal of items replaced by it. If Seller is unable or unwilling to repair or replace, or if repair or replacement does not remedy the nonconformity, Seller and Buyer shall negotiate an equitable adjustment in the contract price, which may include a full refund of the contract price for the nonconforming goods or services. All warranty work shall be performed in a single shift straight time basis Monday through Friday. In the event the Buyer requires correction of warranty items on an overtime schedule, the premium portion of such overtime shall be for the Buyer's account.

THIS IS SELLER'S SOLE GUARANTEE AND WARRANTY WITH RESPECT TO THE GOODS AND SERVICES. THERE ARE NO OTHER EXPRESS OR IMPLIED WARRANTIES OR WARRANTIES OF FITNESS FOR ANY PARTICULAR PURPOSE OR ANY IMPLIED WARRANTIES OF FITNESS FOR ANY PARTICULAR PURPOSE OR ANY IMPLIED WARRANTIES OTHER THAN THOSE MADE EXPRESSLY HEREIN. ALL SUCH WARRANTIES ARE EXPRESSLY DISCLAIMED.

Disclaimers

This manual could contain technical inaccuracies or typographical errors. ADB Airfield Solutions reserves the right to revise this manual from time to time in the contents thereof without obligation of ADB Airfield Solutions to notify any person of such revision or change.

Details and values given in this manual are average values and have been compiled with care. They are not binding, however, and ADB Airfield Solutions disclaims any liability for damages or detriments suffered as a result of reliance on the information given herein or the use of products, processes or equipment to which this manual refers. No warranty is made that the use of the information or of the products, processes or equipment to which this manual refers will not infringe any third party's patents or rights. The information given does not release the buyer from making their own experiments and tests.

Section 1

Safety

2. Introduction

This section contains general safety instructions for using your ADB Airfield Solutions equipment. Some safety instructions may not apply to the equipment in this manual. Task- and equipment-specific warnings are included in other sections of this manual where appropriate. Note all warnings and follow all instructions carefully. Failure to do so may result in personal injury, death, or property damage.

To use this equipment safely,

- refer to the FAA Advisory Circular AC 150/5340-26, *Maintenance of Airport Visual Aids Facilities*, for instructions on safety precautions.
- observe all safety regulations. To avoid injuries, always remove power prior to making any wire connections and touching any parts. Refer to FAA Advisory Circular AC 150/5340-26.
- read and become familiar with the general safety instructions provided in this section of the manual before installing, operating, maintaining, or repairing this equipment.
- read and carefully follow the instructions given throughout this manual for performing specific tasks and working with specific equipment.
- store this manual within easy reach of personnel installing, operating, maintaining, or repairing this equipment.
- follow all applicable safety procedures required by your company, industry standards, and government or other regulatory agencies.
- obtain and read Material Safety Data Sheets (MSDS) for all materials used.

3. Safety Symbols

Become familiar with the safety symbols presented in this section. These symbols will alert you to safety hazards and conditions that may result in personal injury, death, or property and equipment damage.



WARNING: Failure to observe this warning may result in personal injury, death, or equipment damage.



WARNING: Risk of electrical shock. Failure to observe this warning may result in personal injury, death, or equipment damage.



WARNING: Disconnect equipment from line voltage. Failure to observe this warning may result in personal injury, death, or equipment damage.



WARNING: Wear safety goggles. Failure to observe may result in serious injury.



CAUTION: Failure to observe may result in equipment damage.

4. Qualified Personnel

The term *qualified personnel* is defined here as individuals who thoroughly understand the equipment and its safe operation, maintenance, and repair. Qualified personnel are physically capable of performing the required tasks, familiar with all relevant safety rules and regulations and have been trained to safely install, operate, maintain, and repair the equipment. It is the responsibility of the company operating this equipment to see that its personnel meet these requirements.

5. Intended Use



WARNING: Use of this equipment in ways other than described in this manual may result in personal injury, death, or property and equipment damage. Use this equipment only as described in this manual.

ADB Airfield Solutions cannot be responsible for injuries or damages resulting from nonstandard, unintended applications of its equipment. This equipment is designed and intended only for the purpose described in this manual. Uses not described in this manual are considered unintended uses and may result in serious personal injury, death, or property damage. Unintended uses may result from taking the following actions:

- making changes to equipment that have not been recommended or described in this manual or using parts that are not genuine ADB Airfield Solutions replacement parts
- failing to make sure that auxiliary equipment complies with approval agency requirements, local codes, and all applicable safety standards
- using materials or auxiliary equipment that are inappropriate or incompatible with your ADB Airfield Solutions equipment
- allowing unqualified personnel to perform any task

6. Installation

Read the installation section of all system component manuals before installing your equipment. A thorough understanding of system components and their requirements will help you install the system safely and efficiently. **See FAA AC 150/5340-30, Appendix 5, Fig 125 and 126, for sign mounting pad design.**



ATTENTION
**OPTIMAL SIGN INSTALLATION REQUIRES
A FLAT MOUNTING SURFACE**

See Section 3 of the Instruction Manual for detailed Installation Instructions.



WARNING: Failure to follow these safety procedures can result in personal injury or death.

- Allow only qualified personnel to install equipment and use only approved equipment. Using unapproved equipment in an approved system may void agency approvals.
- Make sure all equipment is rated and approved for the environment in which you are using it.
- Follow all instructions for installing components and accessories.
- Install all electrical connections to local code.

5. Installation *(cont)*

- Use only electrical wire of sufficient gauge and insulation to handle the rated current demand. All wiring must meet local codes.
- Route electrical wiring along a protected path. Make sure they will not be damaged by moving equipment.
- Protect components from damage, wear, and harsh environment conditions.
- Allow ample room for maintenance, panel accessibility, and cover removal.
- Protect equipment with safety devices as specified by applicable safety regulations.
- If safety devices must be removed for installation, install them immediately after the work is completed and check them for proper functioning.

7. Operation

Only qualified personnel, physically capable of operating the equipment and with no impairments in their judgment or reaction times, should operate this equipment.

Read all system component manuals before operating this equipment. A thorough understanding of system components and their operation will help you operate the system safely and efficiently.

- Before starting this equipment, check all safety interlocks, fire-detection systems, and protective devices such as panels and covers. Make sure all devices are fully functional. Do not operate the system if these devices are not working properly. Do not deactivate or bypass automatic safety interlocks or locked-out electrical disconnects or pneumatic valves.
- Never operate equipment with a known malfunction.
- Do not attempt to operate or service electrical equipment if standing water is present.
- Use this equipment only in the environments for which it is rated. Do not operate this equipment in humid, flammable, or explosive environments unless it has been rated for safe operation in these environments.
- Never touch exposed electrical connections on equipment while the power is ON.

8. Action in the Event of a System or Component Malfunction

Do not operate a system that contains malfunctioning components. If a component malfunctions, turn the system OFF immediately.

- Disconnect and lock out electrical power.
- Allow only qualified personnel to make repairs. Repair or replace the malfunctioning component according to instructions provided in its manual.

9. Maintenance and Repair

Allow only qualified personnel to perform maintenance, troubleshooting, and repair tasks. Only persons who are properly trained and familiar with ADB Airfield Solutions equipment are permitted to service this equipment.

- Always use safety devices when working on this equipment.
- Follow the recommended maintenance procedures in your equipment manuals.
- Do not service or adjust any equipment unless another person trained in first aid and CPR is present.
- Connect all disconnected equipment ground cables and wires after servicing equipment. Ground all conductive equipment.
- Use only approved ADB Airfield Solutions replacement parts. Using unapproved parts or making unapproved modifications to equipment may void agency approvals and create safety hazards.
- Check interlock systems periodically to ensure their effectiveness.
- Do not attempt to service electrical equipment if standing water is present. Use caution when servicing electrical equipment in a high-humidity environment.
- Use tools with insulated handles when working with electrical equipment.

Section 2

Description

1. Introduction

See Figure 2-1. This section describes the *Signature Series*™ L-858 standard VA, low VA, and fluorescent taxiway and runway signs referred to in Table 2-1.

NOTE: *Signature Series* is a registered trademark of ADB Airfield Solutions.

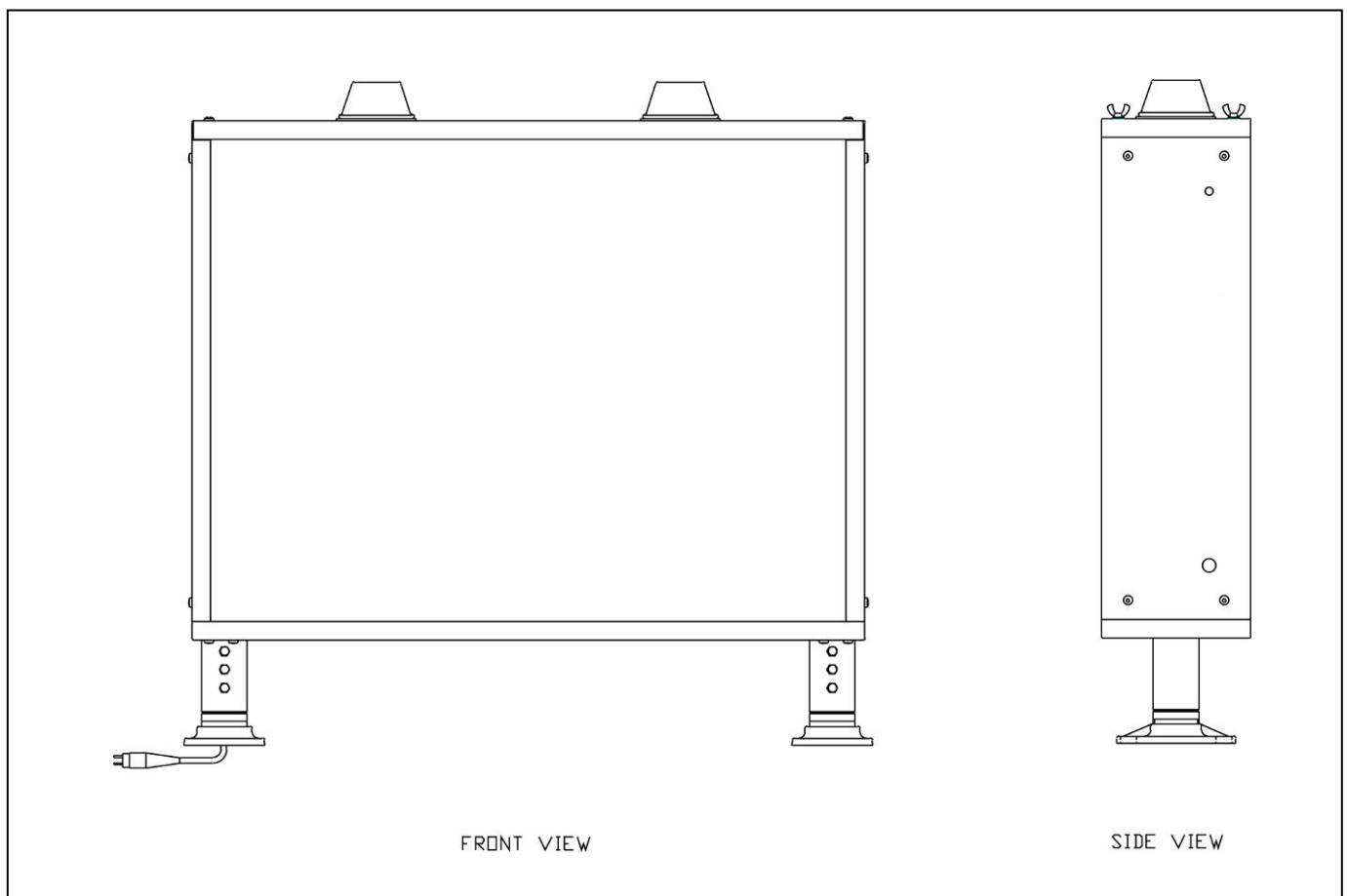

Figure 2-1 L-858 Taxiway and Runway Sign (1-Module)

Table 2-1 L-858 Taxiway and Runway Signs

Sign Type	Purpose	Legend Color	Background Color
L-858Y	Taxiway, Direction, Destination, & Boundary	Black	Yellow
L-858R	Mandatory Sign	White	Red
L-858B	Runway Distance Remaining	White	Black
L-858L	Runway or Taxiway Location	Yellow	Black

1. Introduction *(cont)*

The ADB Airfield Solutions L-858 taxiway and runway signs are used on airports

- to guide pilots of aircraft to destinations in accordance with FAA AC 150/5340-18
- to identify holding positions, intersecting runways and taxiways
- to prohibit entry into a particular area
- to provide runway distance remaining information to pilots during takeoff and landing operations

The basic sign module accommodates two characters and can be single- or double-faced. The signs are available in all FAA classifications of various lengths depending on the number of modules combined. Each sign is furnished complete with lamp(s), connecting leads, legend panels, brightness control transformer(s), and mounting assemblies designed for installation on concrete pads.

NOTE: MR16 quartz lamps are standard for L-858 taxiway and runway signs. Optional fluorescent lamps are also available.

2. Optional Equipment

This subsection discusses optional equipment. Optional equipment includes the Lamps-Out Indicator and the On/Off switch.

Optional Lamps-Out Indicator (Halogen Signs Only)

The Lamps-Out Indicator (LOI) is an optional component used in conjunction with the Signature Series sign electronics to give a visual indication that a lamp has failed. This allows airport personnel to quickly find a sign with a failed lamp. The LOI flashes a small blue LED with a narrow field of view designed for direct viewing only from one side of the sign at eye level or from the seat of a truck so that pilots are not distracted.

During operation, the Signature Series sign electronics constantly monitors whether a lamp has failed. When a lamp fails, the sign electronics sends a signal to the LOI indicating that a lamp has failed. The LOI immediately starts charging its capacitors through the sign electronics. When the LOI has reached sufficient charge, the LED mounted on one side of the sign starts to flash at a rate of once every two seconds, with or without the sign being powered. At full charge (approximately 6 hours), the LOI flashes, without the sign being powered, for approximately 24 hours. The LOI continues to flash until the failed lamp has been replaced and the sign power cycled on.

Optional Lamps-Out Indicator (*cont*)

The LOI LED can be set to one of three intensity levels: Low, Medium, and High. The different levels are intended to cover a wide range of viewing conditions such as weather, night or day viewing, and distance.

For more information on installing and operating the Lamps-Out Indicator, refer to *Optional Lamps-Out Indicator Mounting* in the *Installation* section.

Optional On/Off Switch

See Figure 2-2. The optional push button On/Off switch can be used to turn off the sign directly at the sign to service the sign on an active airfield circuit. In the Off position, the switch shorts the secondary of the isolation transformer. Refer to the *Parts* section for the part number.

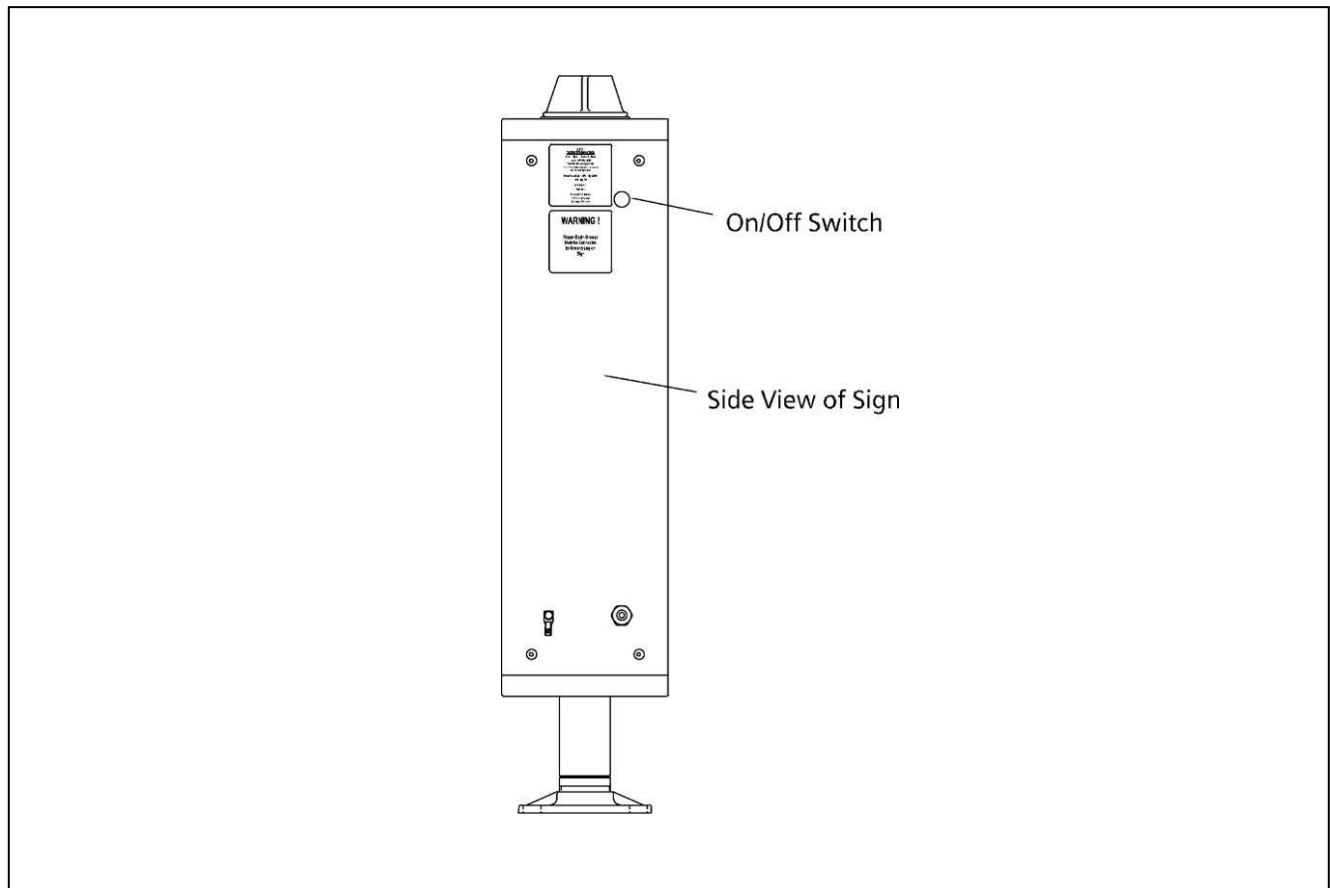

Figure 2-2 Optional On/Off Switch

2. L-858 Signs: Required Equipment

Refer to Table 2-2 for required equipment that is supplied. Refer to Table 2-3 for required equipment that is not supplied.

Table 2-2 Required Equipment Supplied

Description	Quantity
L-858 sign	As required
Instruction manual	2 per order
L-858 tether assembly	As required

Table 2-3 Required Equipment Not Supplied

Description	Quantity
L-867 base	1
L-828 constant current regulator	1
L-830 isolation transformer	1
L-824 cable	As required
Connectors	As required
Anchor bolts (two 1/2–13 bolts per foot)	As required
Anti-seize compound/petroleum jelly	As required
Level (spirit or digital)	1

3. Specifications

This subsection provides specifications for L-858 taxiway and runway signs.

Rated Lamp Life

Rated lamp life for 48 W halogen lamps is 1500 hours at full power. Since the 48 W lamps are run at a reduced power of 6.0-6.2 A, actual lamp life may be up to 8,000 hours. 18W fluorescent lamps are rated at 12,000 hours.

Construction

Structure is fabricated from aluminum extrusions. Mounting hardware is stainless steel.

Visibility

Sign type is discernible at nighttime up to a distance of 800 feet (243.84 m). Average luminance of 10 to 30 ft-lamberts (34.26–102.78 candelas per square meter) on all types and styles.

Style

Refer to Table 2-4 for sign style.

Table 2-4 Sign Style

Style	Size	Power Source
2	1, 2, 3, 4 and 5	Powered from 4.8 to 6.6 A CCR
3	1, 2, 3, 4 and 5	Powered from 2.8 to 6.6 A CCR
5	1, 2, 3, 4, and 5	Powered from a 3 step CCR set to B30.

Class

Refer to Table 2-5 for sign class.

NOTE: All ADB Airfield Solutions halogen lamp signs meet Class 2 requirements. The fluorescent lamp signs meet Class 1.

Table 2-5 Sign Class

Class	Operating Temperature Range (Celsius)	Operating Temperature Range (Fahrenheit)
1	-20 to +55 °C	-4 to +131 °F
2	-55 to +55 °C	-67 to +131 °F

Conditions for Continuous Outdoor Use

The L-858 taxiway and runway sign is designed for continuous outdoor use under the conditions presented below for operating temperature range, wind, and rain.

Operating Temperature Range

-55 to +55 °C (-67 to +131 °F) (Halogen)
-20 to +55 °C (-4 to +131 °F) (Fluorescent)

Wind

Withstands [225 MPH (362.1 KPH)] [0.9 PSI (6205 N/m²)] wind. Frangible couplings fail before reaching 1.3 PSI (8963 N/m²) [270 MPH (434.5 KPH)]. Special high wind signs are also available.

Rain

The L-858 taxiway and runway sign is designed for exposure to driving rains.

Sign Classification

Refer to Table 2-6 for sign classification. Refer to AC 150/5345-44.

Table 2-6 Sign Classification

Sign Type	Sign Size	Sign Face Height in. (mm)	Legend Height in. (mm)	Style Numbers	Class Numbers	Overall Mounting Height in. (mm)
L-858Y/R/L	1	18 (460)	12 (300)	2, 3, 5	1, 2	24-30 (610-760)
L-858Y/R/L	2	24 (610)	15 (380)	2, 3, 5	1, 2	30-36 (760-910)
L-858Y/R/L	3	30 (760)	18 (460)	2, 3, 5	1, 2	36-42 (910-1070)
L-858B	4	48 (1220)	40 (1020)	2, 3, 5	1, 2	54-60 (1370-1520)
L-858B	5	30 (760)	25 (640)	2, 3, 5	1, 2	36-42 (910-1070)

Number of Lamps Per Module

This subsection provides for the number of lamps per module.

Refer to Table 2-7.

Table 2-7 Number of Lamps Per Module (Style 2 and 3)

Sign Size	MR-16/48 W and 18W Fluorescent Lamps Required
1	1 per module
2	2 per module
3 & 5	2 per module
4	4 per module

Modular Combination Lengths

Refer to Table 2-8 for modular combination lengths.

Table 2-8 Modular Combination Lengths

Sign Size	1 Module in. (mm)	2 Modules in. (mm)	3 Modules in. (mm)	4 Modules in. (mm)	Maximum Length Allowed in. (mm)
1	29.34 (745.23)	58.62 (1489.00)	87.90 (2232.7)	117.17 (2976.1)	120 (3048)
2	35.84 (910.3)	71.62 (1819.2)	107.40 (2728.0)	143.17 (3636.5)	145 (3683)
3	42.34 (1075.4)	84.62 (2149.4)	126.90 (3223.3)	169.17 (4296.9)	170 (4318)
4	47.84 (1215.1)	Not applicable	Not applicable	Not applicable	Not applicable
5	42.34 (1075.4)	Not applicable	Not applicable	Not applicable	Not applicable

Frangibility

All signs sustain a static load of 0.9 PSI (6205 N/m²) uniformly [225 MPH (362.1 KPH) wind] over the entire surface of the sign and break over before reaching 1.3 PSI (8963 N/m²) [270 MPH (434.5 KPH) wind].

Dimensions

This subsection describes the dimensions for the L-858 signs. L-858 signs come in Sizes 1, 2, and 3 with one to four modules, and Sizes 4 and 5 with one module.

Sizes 1, 2, 3, and 5

See Figures 2-3 through 2-6 for Sizes 1, 2, 3, and 5. Refer to Tables 2-9 through 2-12 for the dimensions for all sizes and modules.

NOTE: See Figure 2-3 for dimension A, the overall mounting height, for all sizes and modules.

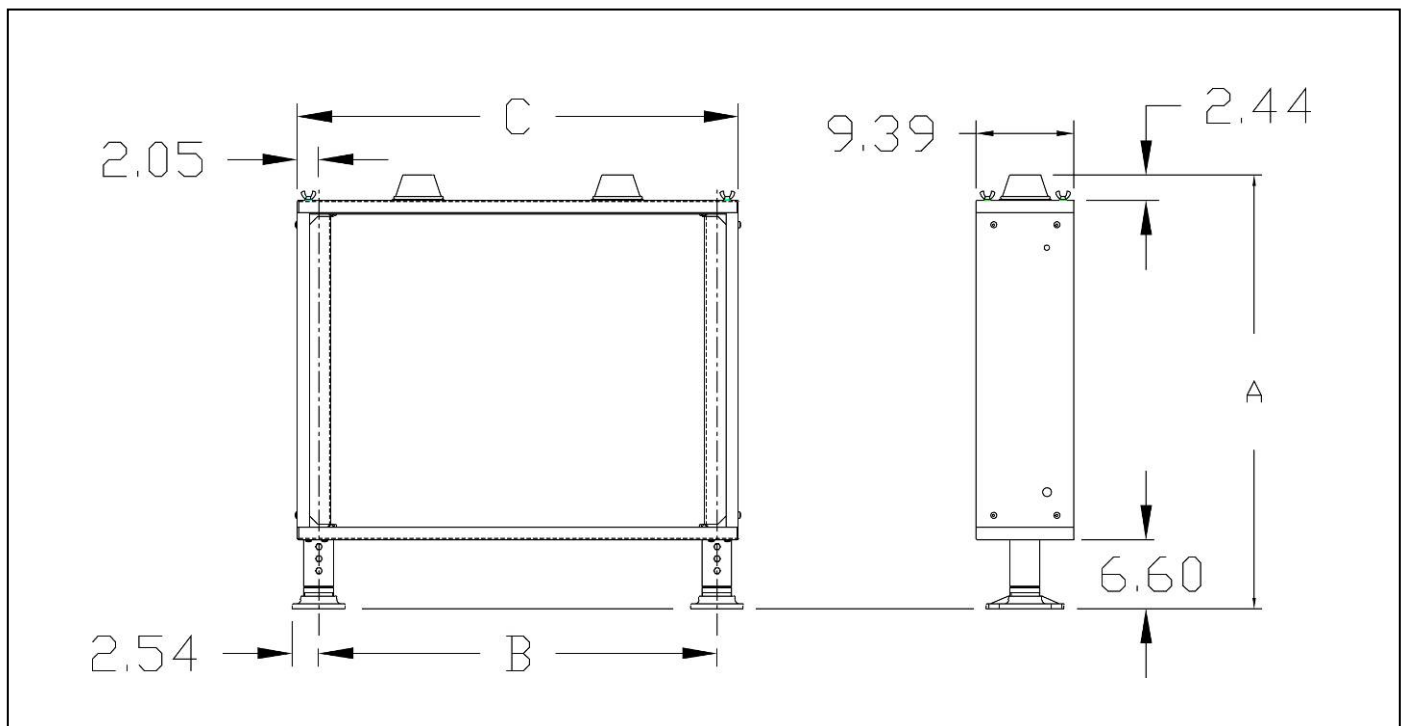

Figure 2-3 L-858 Sign Dimensions (Sizes 1, 2, 3, and 5/One-Module)

Sizes 1, 2, 3, and 5 (*cont*)

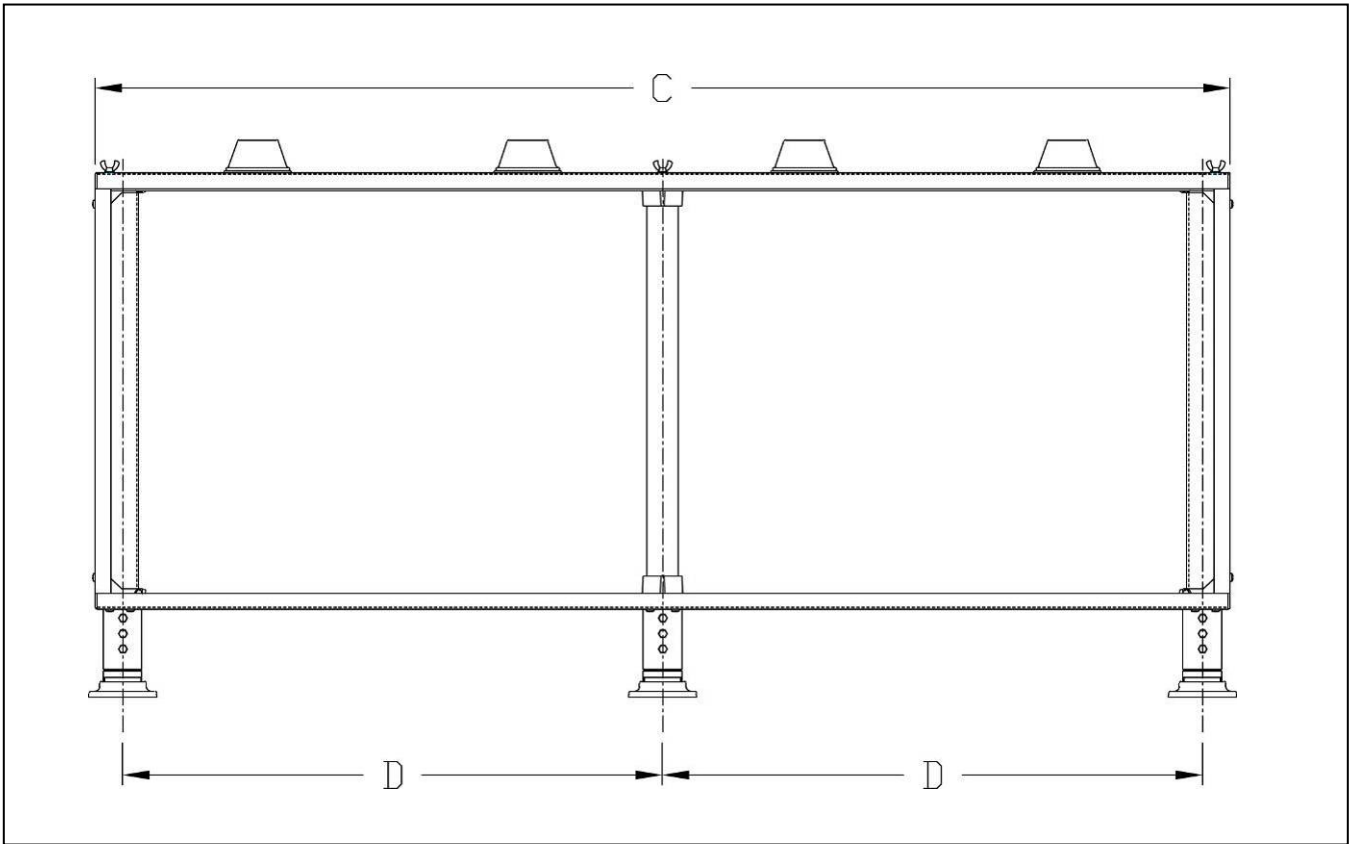

Figure 2-4 L-858 Sign Dimensions (Sizes 1, 2, 3/Two-Module)

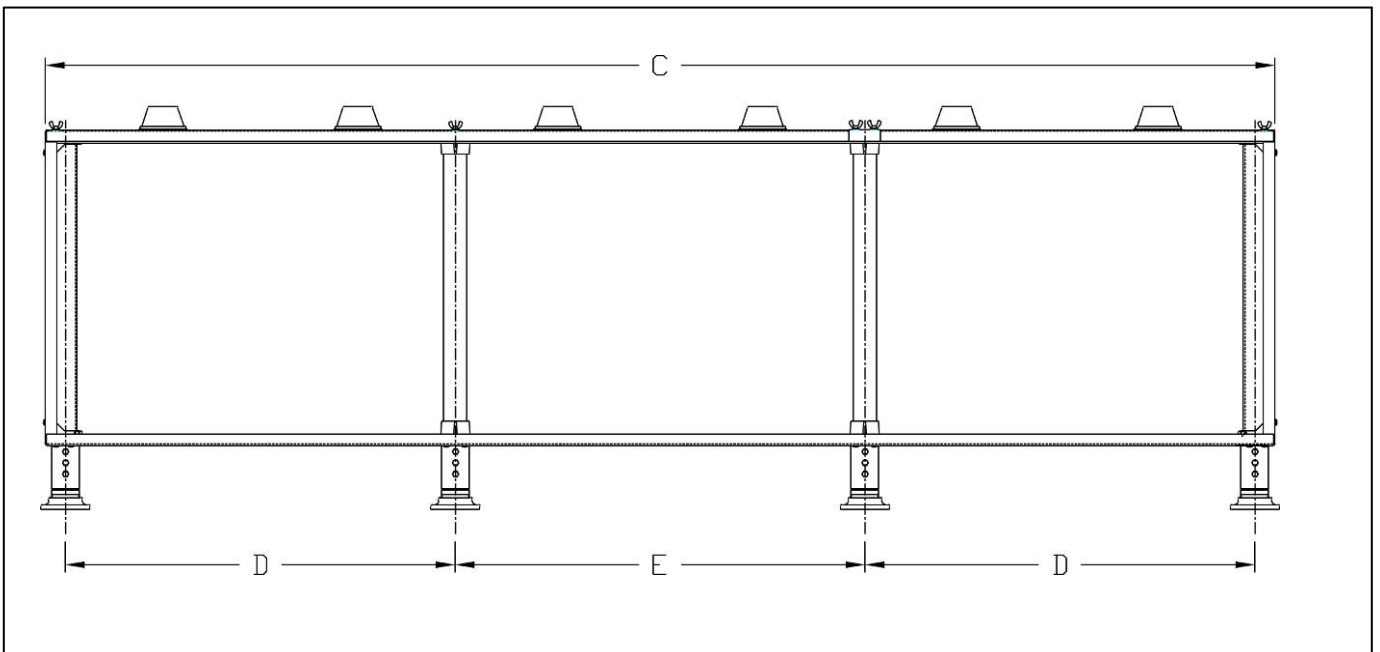

Figure 2-5 L-858 Sign Dimensions (Sizes 1, 2, 3/Three-Module) L-858 Sign Dimensions (Sizes 1, 2, 3/Three-Module)

Sizes 1, 2, 3, and 5 (cont)

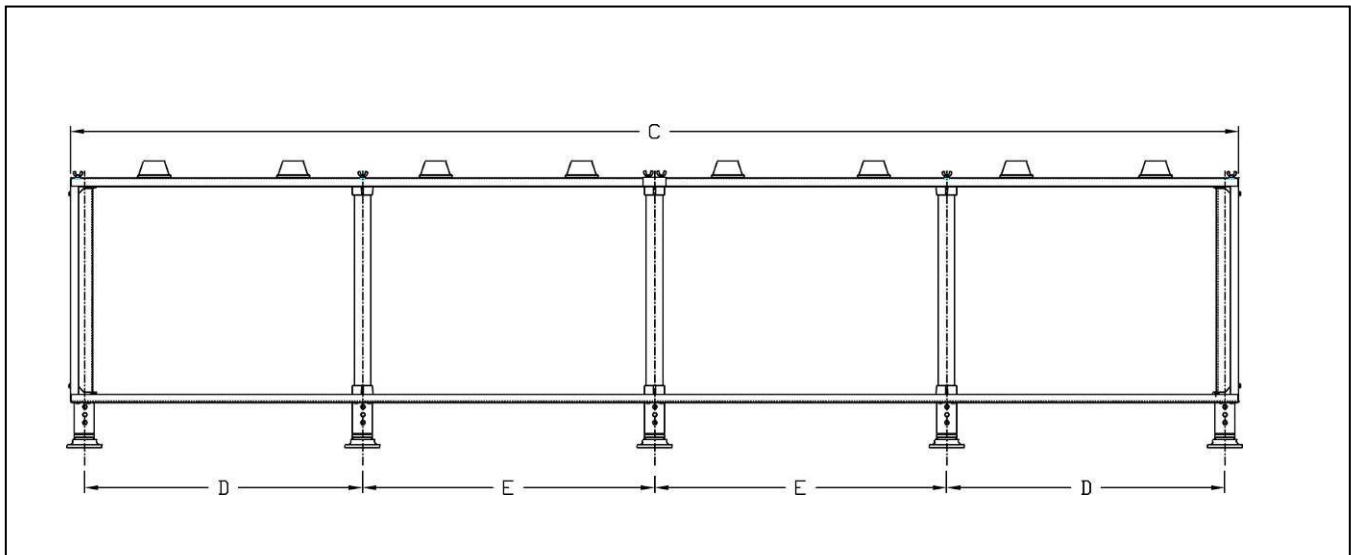

Figure 2-6 L-858 Sign Dimensions (Sizes 1, 2, 3/4-Module)

Table 2-9 L-858 Size 1 Sign Dimensions

Sign Size	A in. (mm)	B in. (mm)	C in. (mm)	D in. (mm)	E in. (mm)	Number of Lamps/Modules
Size 1, 1-Module	29.68 (753.9)	25.23 (640.8)	29.34 (745.23)	Not applicable	Not applicable	1
Size 1, 2 Module	29.68 (753.9)	Not applicable	58.62 (1489.00)	27.26 (692.4)	Not applicable	1
Size 1, 3-Module	29.68 (753.9)	Not applicable	87.90 (2232.7)	27.26 (692.4)	29.28 (743.7)	1
Size 1, 4-Module	29.68 (753.9)	Not applicable	117.17 (2976.1)	27.26 (692.4)	29.28 (743.7)	1

Table 2-10 L-858 Size 2 Sign Dimensions

Sign Size	A in. (mm)	B in. (mm)	C in. (mm)	D in. (mm)	E in. (mm)	Number of Lamps/Modules
Size 2, 1-Module	35.68 (906.3)	31.73 (805.9)	35.84 (910.3)	Not applicable	Not applicable	2
Size 2, 2 Module	35.68 (906.3)	Not applicable	71.62 (1819.2)	33.76 (857.5)	Not applicable	2
Size 2, 3-Module	35.68 (906.3)	Not applicable	107.40 (2728.0)	33.76 (857.5)	35.79 (909.1)	2
Size 2, 4-Module	35.68 (906.3)	Not applicable	143.17 (3636.5)	33.76 (857.5)	35.79 (909.1)	2

Sizes 1, 2, 3, and 5 (cont)

Table 2-11 L-858 Size 3 Sign Dimensions

Sign Size	A in. (mm)	B in. (mm)	C in. (mm)	D in. (mm)	E in. (mm)	Number of Lamps/Modules
Size 3, 1-Module	41.68 (1058.7)	38.23 (971.0)	42.34 (1075.4)	Not applicable	Not applicable	2
Size 3, 2 Module	41.68 (1058.7)	Not applicable	84.62 (2149.4)	40.26 (1022.6)	Not applicable	2
Size 3, 3-Module	41.68 (1058.7)	Not applicable	126.90 (3223.3)	40.26 (1022.6)	42.28 (1073.9)	2
Size 3, 4-Module	41.68 (1058.7)	Not applicable	169.17 (4296.9)	40.26 (1022.6)	42.28 (1073.9)	2

Table 2-12 L-858 Size 5 Sign Dimensions

Sign Size	A in. (mm)	B in. (mm)	C in. (mm)	D in. (mm)	E in. (mm)	Number of Lamps/Modules
Size 5, 1-Module	41.68 (1058.7)	38.24 (971.3)	42.34 (1075.4)	Not applicable	Not applicable	2

Size 4

See Figure 2-7 for Size 4 sign. Refer to Table 2-13 for dimensions.

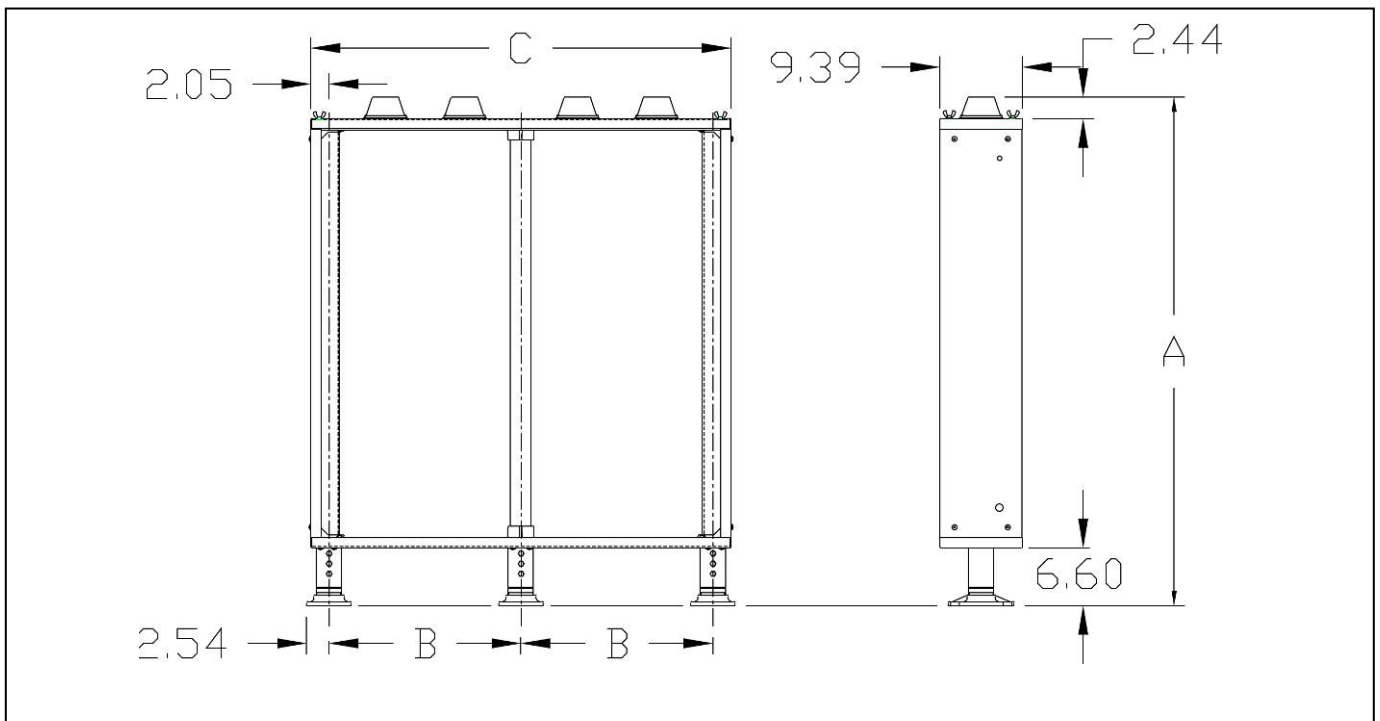

Figure 2-7 L-858 Sign Dimensions (Size 4/One-Module)

Size 4 (cont)

Table 2-13 L-858 Size 4 Sign Dimensions

Sign Size	A in. (mm)	B in. (mm)	C in. (mm)	Number of Lamps/Modules
Size 4, 1-Module	58.13 (1476.5)	21.87 (555.5)	47.84 (1215.1)	4

Sign Power Factor and Total
VA Load

Refer to Tables 2-14 through 2-19. The electrical load specification is located on the sign nameplate.

NOTE: The number for the total VA load imposed on CCR represents the actual load imposed on the regulator and accounts for power factor and load imposed by the L-830 transformer. Use this number when calculating regulator wattage to be used. You cannot determine this number by totaling nominal lamp wattage. See Tables 2-22 and 2-23.

Table 2-14 (1-step) Sign Power Factor and VA Load (Using 48 W/MR16 Lamps)

Sign Size	No. of Modules	L-830 Transformer	No. of 48 W Lamps	Sign Power Factor	Volt Amp VA Load
1	1	L-830-1, 45 W	1	0.99	48
1	2	L-830-4, 100 W	2	0.99	96
1	3	L-830-6, 200 W	3	0.99	144
1	4	L-830-6, 200 W	4	0.99	192
2	1	L-830-4, 100 W	2	0.99	96
2	2	L-830-6, 200 W	4	0.99	192
2	3	L-830-10, 300 W	6	1.00	288
2	4	6.6 A/6.6 A, 500 W	8	0.98	384
3	1	L-830-4, 100 W	2	0.99	96
3	2	L-830-6, 200 W	4	0.99	192
3	3	L-830-10, 300 W	6	1.0	288
3	4	6.6 A/6.6 A, 500 W	8	0.98	384
4	1	L-830-6, 200 W	4	0.99	192
5	1	L-830-4, 100 W	2	0.99	96

Table 2-15 5 (1-step) Sign Power Factor and VA Load (Using 18W fluorescent lamps)

Sign Size	No. of Modules	L-830 Transformer	No. of 18W Lamps	Sign Power Factor	Volt Amp VA Load
1	1	L-830-4, 100W	1	0.96	57
1	2	L-830-4, 100W	2	0.95	77
1	3	L-830-4, 100W	3	0.93	96
1	4	L-830-6, 200 W	4	0.93	116
2,3	1	L-830-4, 100W	2	0.95	77
2,3	2	L-830-6, 200 W	4	0.93	116
2,3	3	L-830-6, 200 W	6	0.92	158
2,3	4	L-830-10, 300 W	8	0.93	192
4	1	L-830-6, 200 W	4	0.93	116
5	1	L-830-4, 100W	2	0.95	77

Table 2-16 Low VA Style 2 (3-Step) Sign Power Factor and VA Load (Using 48W/MR16 Lamps)

Sign Size	No. of Modules	L-830 Transformer	No. of 48 W Lamps	Sign Power Factor	Volt Amp VA Load
1	1	L-830-4, 100 W	1	0.98	106
1	2	L-830-6, 200 W	2	0.99	155
1	3	L-830-10, 300 W	3	0.98	202
1	4	L-830-10, 300 W	4	0.99	250
2,3	1	L-830-6, 200 W	2	0.99	155
2,3	2	L-830-10, 300 W	4	0.99	250
2,3	3	6.6 A/6.6 A, 500 W	6	0.98	340
2,3	4	2 Ea L-830-10s, 300 W	8	0.97	450
4	1	L-830-10, 300 W	4	0.99	250
5	1	L-830-6, 200 W	2	0.99	155

Table 2-17 Style 2 (3-Step) Sign Power Factor and VA Load (Using 18W fluorescent lamps)

Sign Size	No. of Modules	L-830 Transformer	No. of 18W Lamps	Sign Power Factor	Volt Amp VA Load
1	1	L-830-6, 200W	1	0.96	68
1	2	L-830-6, 200W	2	0.95	88
1	3	L-830-6, 200W	3	0.93	106
1	4	L-830-6, 200W	4	0.93	127
2,3	1	L-830-6, 200W	2	0.95	88
2,3	2	L-830-6, 200W	4	0.93	127
2,3	3	L-830-10, 300W	6	0.92	172
2,3	4	L-830-10, 300W	8	0.93	203
4	1	L-830-6, 200W	4	0.93	127
5	1	L-830-6, 200W	2	0.95	88

Table 2-18 Style 3 (5-Step) Sign Power Factor and VA Load (Using 48 W/MR16 Lamps)

Sign Size	No. of Modules	L-830 Transformer	No. of 48 W Lamps	Sign Power Factor	Volt Amp VA Load
1	1	L-830-6, 200 W	1	0.97	105
1	2	L-830-10, 300 W	2	0.98	145
1	3	6.6 A/6.6 A, 500 W	3	0.98	190
1	4	6.6 A/6.6 A, 500 W	4	0.98	233
2,3	1	L-830-10, 300 W	2	0.98	145
2,3	2	6.6 A/6.6 A, 500 W	4	0.98	233
2,3	3	1 Ea 6.6 A/6.6 A, 500 W 1 Ea L-830-10, 300 W	6	0.98	350
2,3	4	2 Ea 6.6 A/6.6 As, 500 W	8	0.97	440
4	1	6.6 A/6.6 A, 500 W	4	0.98	233
5	1	L-830-10, 300 W	2	0.98	145

Table 2-19 3 (5-Step) Sign Power Factor and VA Load (Using 18W fluorescent lamps)

Sign Size	No. of Modules	L-830 Transformer	No. of 18W Lamps	Sign Power Factor	Volt Amp VA Load
1	1	L-830-6, 200W	1	0.96	68
1	2	L-830-6, 200W	2	0.95	88
1	3	L-830-6, 200W	3	0.93	106
1	4	L-830-10, 300W	4	0.93	127
2,3	1	L-830-6, 200W	2	0.95	88
2,3	2	L-830-10, 300W	4	0.93	127
2,3	3	6.6A – 6.6A 500W	6	0.92	172
2,3	4	6.6A – 6.6A 500W	8	0.89	199
4	1	L-830-10, 300W	4	0.93	127
5	1	L-830-6, 200W	2	0.95	88

Table 2-20 Standard VA Style 3 (3-Step) Sign Power Factor and VA Load (Using 48W/MR16 Lamps)

Sign Size	No. of Modules	L-830 Transformer	No. of 48W Lamps	Sign Power Factor	Volt Amp VA Load
1	1	L-830-1, 30/45W	1	0.59	104
1	2	L-830-4, 100 W	2	0.46	222
1	3	L-830-4, 100 W	3	0.52	302
1	4	L-830-6, 200 W	4	0.52	319
2,3	1	L-830-4,100W	2	0.46	222
2,3	2	L-830-6, 200 W	4	0.52	319
2,3	3	L-830-10, 300W	6	0.48	460
2,3	4	L-830-10, 300W	8	0.53	570
4	1	L-830-6, 200 W	4	0.52	319
5	1	L-830-4, 100W	2	0.46	222

Table 2-21 VA Style 3 (5-Step) Sign Power Factor and VA Load (Using 48W/MR16 Lamps)

Sign Size	No. of Modules	L-830 Transformer	No. of 48W Lamps	Sign Power Factor	Volt Amp VA Load
1	1	L-830-4, 100W	1	0.21	231
1	2	L-830-6, 200 W	2	0.32	316
1	3	L-830-10, 300W	3	0.24	641
1	4	6.6A – 6.6A, 500W	4	0.31	652
2,3	1	L-830-6,200W	2	0.32	316
2,3	2	L-830-10, 300 W	4	0.21	652
2,3	3	2 Ea L-830-10, 300W	6	0.20	1150
2,3	4	2 Ea L-830-10, 300W	8	0.31	1304
4	1	6.6A – 6.6A, 500W	4	0.31	652
5	1	L-830-10, 300W	2	0.32	316

NOTE: In Table 2-22, select KVA greater than or equal to the non-sign load (edge lights, cable losses, etc.) from the left-hand column.

NOTE: Read across Table 2-22 to KVA greater than or equal to the low VA sign load. Numbers for low VA sign load are show in KVA. Required CCR rating is shown at the top of the column.

Table 2-22 3-Step Circuit CCR Selection Table

Non sign Load (KVA)								
	4 KW	7.5 KW	10 KW	15 KW	20 KW	30 KW	50 KW	70 KW
0.5	2.71	5.25	7.07	10.71	14.34	21.61		
1	2.50	5.05	6.86	10.50	14.14	21.41		
1.5	2.30	4.84	6.66	10.30	13.93	21.21	50 and 70 KW units are 5-step, 20 A only.	
2	2.00	4.64	6.46	10.10	13.73	21.00		
2.5	1.50	4.43	6.25	9.89	13.53	20.80		
3	1.00	4.23	6.05	9.69	13.32	20.59		
3.5	0.50	4.00	5.85	9.48	13.12	20.39		
4	0.00	3.50	5.64	9.28	12.91	20.19		
4.5	-	3.00	5.44	9.08	12.71	19.98		
5	-	2.50	5.00	8.87	12.51	19.78		
5.5	-	2.00	4.50	8.67	12.30	19.58		
6	-	1.50	4.00	8.47	12.10	19.37		
6.5	-	1.00	3.50	8.26	11.90	19.17		
7	-	0.50	3.00	8.00	11.69	18.97		
7.5	-	0.00	2.50	7.50	11.49	18.76		
8	-	-	2.00	7.00	11.29	18.56		
8.5	-	-	1.50	6.50	11.08	18.35		
9	-	-	1.00	6.00	10.88	18.15		
9.5	-	-	0.50	5.50	10.50	17.95		
10	-	-	0.00	5.00	10.00	17.74		
11	-	-	-	4.00	9.00	17.34		
12	-	-	-	3.00	8.00	16.93		
13	-	-	-	2.00	7.00	16.52		
14	-	-	-	1.00	6.00	16.00		
15	-	-	-	0.00	5.00	15.00		
16	-	-	-	-	4.00	14.00		
17	-	-	-	-	3.00	13.00		
18	-	-	-	-	2.00	12.00		
19	-	-	-	-	1.00	11.00		
20	-	-	-	-	0.00	10.00		
22	-	-	-	-	-	8.00		
24	-	-	-	-	-	6.00		
26	-	-	-	-	-	4.00		
28	-	-	-	-	-	2.00		
30	-	-	-	-	-	0.00		
35								
40			50 and 70 KW units are 5-step, 20 A only.					
45								
50								
55								
60								
65								
70								

NOTE: In Table 2-22, select KVA greater than or equal to the non-sign load (edge lights, cable losses, etc.) in the left-hand column.

NOTE: Read across Table 2-22 to KVA greater than or equal to the low VA sign load. Numbers for low VA sign load are show in KVA. Required CCR rating is shown at the top of the column.

NOTE: In Table 2-23, the shaded area is provided for information only. Most 5-step circuits will not fall in this area.

Table 2-23 5-Step Circuit CCR Selection Table

Non sign Load (KVA)	5-Step Circuit CCR Selection Table							
	4 KW	7..5 KW	10 KW	15 KW	20 KW	30 KW	50 KW	70 KW
0.5	1.65	3.14	4.20	6.32	8.44	12.68	21.17	29.65
1	1.61	3.09	4.15	6.28	8.39	12.64	21.12	29.61
1.5	1.56	3.05	4.11	6.23	8.35	12.59	21.08	29.56
2	1.52	3.00	4.06	6.19	8.31	12.55	21.03	29.52
2.5	1.47	2.96	4.02	6.14	8.26	12.50	20.99	29.47
3	1.00	2.91	3.97	6.10	8.22	12.46	20.95	29.43
3.5	0.50	2.87	3.93	6.05	8.17	12.41	20.90	29.38
4	0.00	2.82	3.89	6.01	8.13	12.37	20.86	29.34
4.5	-	2.78	3.84	5.96	8.08	12.33	20.81	29.30
5	-	2.50	3.80	5.92	8.04	12.28	20.77	29.25
5.5	-	2.00	3.75	5.87	7.99	12.24	20.72	29.21
6	-	1.50	3.71	5.83	7.95	12.19	20.68	29.16
6.5	-	1.00	3.50	5.79	7.90	12.15	20.63	29.12
7	-	0.50	3.00	5.74	7.86	12.10	20.59	29.07
7.5	-	0.00	2.50	5.70	7.82	12.06	20.54	29.03
8	-	-	2.00	5.65	7.77	12.01	20.50	28.98
8.5	-	-	1.50	5.61	7.73	11.97	20.46	28.94
9	-	-	1.00	5.56	7.68	11.92	20.41	28.89
9.5	-	-	0.50	5.50	7.64	11.88	20.37	28.85
10	-	-	0.00	5.00	7.59	11.84	20.32	28.81
11	-	-	-	4.00	7.50	11.75	20.23	28.72
12	-	-	-	3.00	7.41	11.66	20.14	28.63
13	-	-	-	2.00	7.00	11.57	20.05	28.54
14	-	-	-	1.00	6.00	11.48	19.97	28.45
15	-	-	-	0.00	5.00	11.39	19.88	28.36
16	-	-	-	-	4.00	11.30	19.79	28.27
17	-	-	-	-	3.00	11.21	19.70	28.18
18	-	-	-	-	2.00	11.12	19.61	28.00
19	-	-	-	-	1.00	11.00	19.52	27.91
20	-	-	-	-	0.00	10.00	19.43	27.74
22	-	-	-	-	-	8.00	19.25	27.56
24	-	-	-	-	-	6.00	19.07	27.38
26	-	-	-	-	-	4.00	18.90	27.20
28	-	-	-	-	-	2.00	18.72	27.02
30	-	-	-	-	-	0.00	18.54	26.58
35	-	-	-	-	-	-	15.00	26.13
40	-	-	-	-	-	-	10.00	25.00
45	-	-	-	-	-	-	5.00	20.00
50	-	-	-	-	-	-	0.00	15.00
55	-	-	-	-	-	-	-	10.00
60	-	-	-	-	-	-	-	5.00
65	-	-	-	-	-	-	-	0.00
70	-	-	-	-	-	-	-	

Sign Weight**Table 2-24 Sign Weight**

Size / Module	Weight lb (kg)
Size 1/1-module	46 (20.87)
Size 1/2-module	78 (35.38)
Size 1/3-module	115 (52.16)
Size 2/2-module	104 (47.17)
Size 2/3-module	153 (69.40)
Size 3/1-module	81 (36.74)
Size 3/2-module	131 (59.42)
Size 3/3-module	199 (90.27)
Size 3/4-module	252 (114.30)
Size 4/ 1-module	122 (55.34)

Section 3

Installation



WARNING: Allow only qualified personnel to perform the following tasks. Observe and follow the safety instructions in this document and all other related documentation.



ATTENTION: SIGN INSTALLATION REQUIRES A FLAT MOUNTING SURFACE AND THE SIGN TO BE LEVEL TO PREVENT LEGEND PANELS FROM BECOMING DISTORTED.

FAILURE TO INSTALL AND LEVEL SIGN PER SECTION 3 OF THE INSTRUCTION MANUAL WILL VOID THE WARRANTY

See Sub-Section 4, Installation, Sign Mounting, page 4-11 for detailed instructions. Also see FAA AC 150/5340-30, Figure 126, for concrete base design.

1. Introduction

This section provides instructions for installing L-858 taxiway and runway signs. Refer to the airport project plans and specifications for the specific installation instructions and FAA AC 150/5340-18.

2. Unpacking

The equipment is shipped ready for installation. Handle equipment very carefully to prevent component damage. Unpack the carton upon receipt and check the contents and their condition. Note any exterior damage to the carton that might lead to detection of equipment damage.

If you note any damage to any equipment, file a claim with the carrier immediately. The carrier may need to inspect the equipment.

3. Cord set Installation

This subsection provides information for installing cord sets. It includes sign installation kit reference numbers for three power leg cord set installation locations and mounting configurations.

Cord set Installation Reference Numbers

This subsection provides special cord set locations with parts and part numbers. See Figure 3-1 for the ordering code for the L-858 sign. Special cords set installation reference numbers are located in the ordering code.

Cord set Installation

Reference Numbers (*cont*)

Cord set Exit Location #1

Figure 3-1 shows cord set location #1. Refer to Table 3-1 for cord set location #1 parts and part numbers.

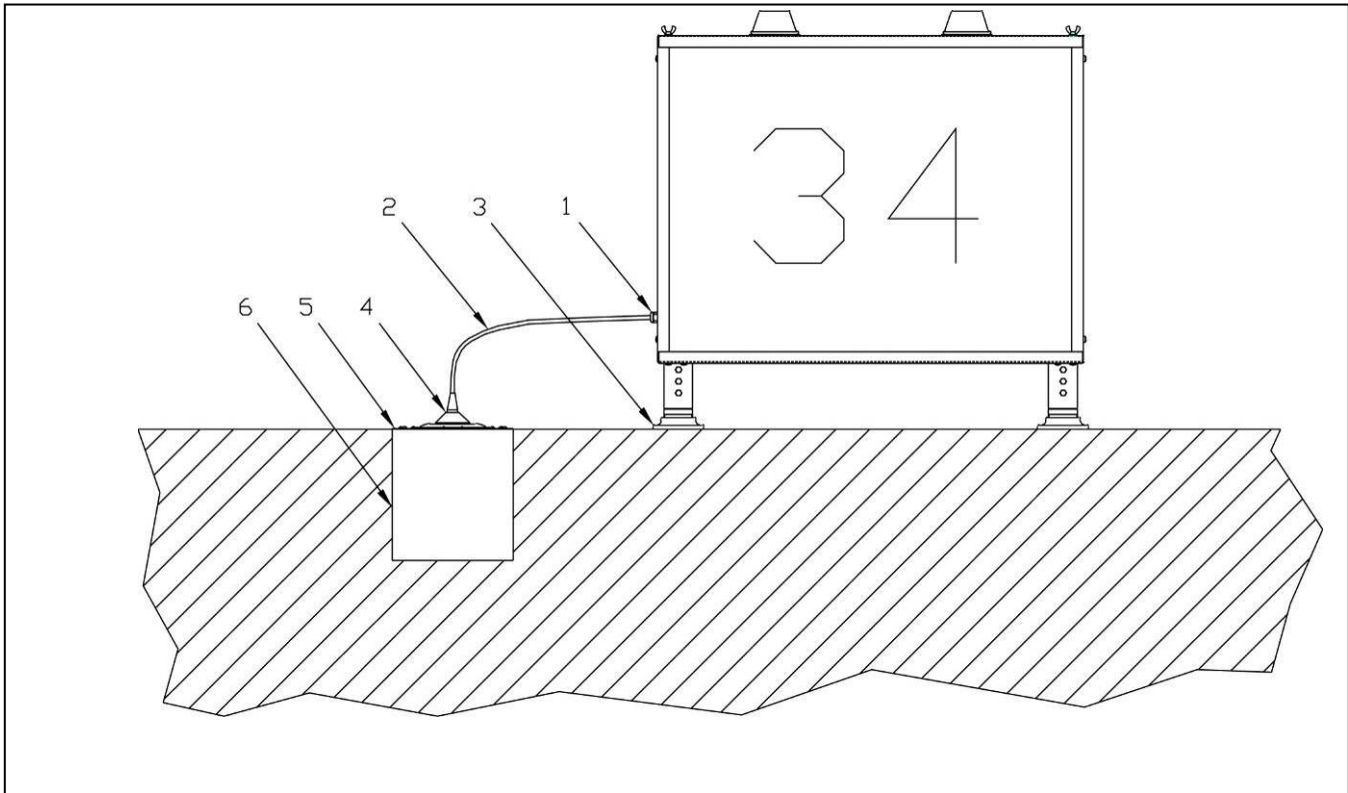

Figure 3-1 Cord set Location #1 (Non-typical)

Table 3-1 Cord set Location #1 Parts

Item	Description	Supplier	Part Number	Note
1	Strain relief	ADB Airfield Solutions	77A0156	A
2	Cord set 16/2 SOW 600 V	ADB Airfield Solutions	Supplied with sign	B
3	Base flange	ADB Airfield Solutions	62A2142 or 62A2146	A
4	Connector plug	ADB Airfield Solutions	63B0550	C
5	2-in. (50.8-mm) L-867 base plate	ADB Airfield Solutions	1932	C
6	12 x 24 in. (304.8 x 609.6 mm) L-867B base	ADB Airfield Solutions	2124	C

NOTE A: Shown for reference only. Part supplied with sign.

NOTE B: Signs supplied with the following length external to the sign: Size 1 = 47 in. Size 2 = 41 in.

Size 3 = 35 in. Size 4 = 18 in. Size 5 = 35 in. Any other external length requires a separate line on the purchase order specifying the external length required.

NOTE C: Requires a separate line item on the purchase order.

Cord set Exit Location #2

Figure 3-2 shows cord set location #2. Refer to Table 3-2 for cord set location #2 parts and part numbers.

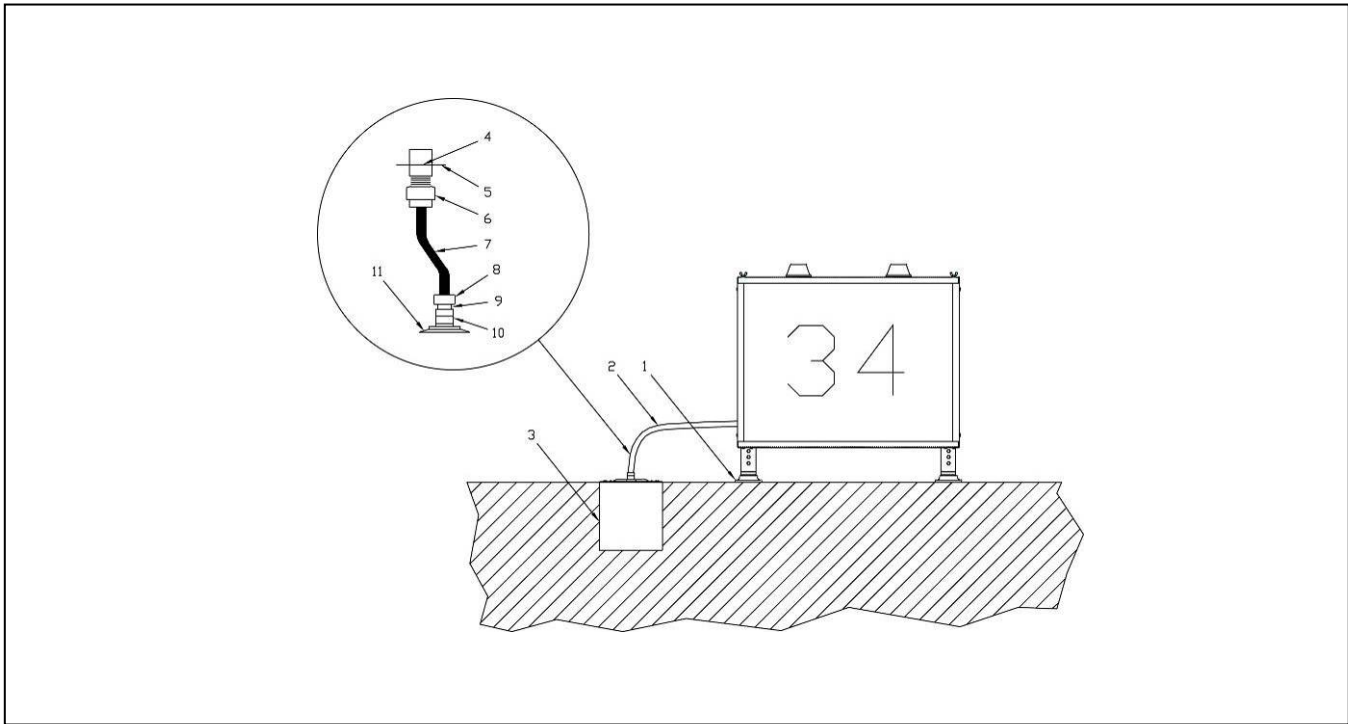

Figure 3-2 Cord set Location #2 (Non-typical)

Table 3-2 Cord set Location #2 Parts

Item	Description	Supplier	Part Number	Note
1	Base flange	ADB Airfield Solutions	62A2142 or 62A2146	D
2	L-823 cord set 16/2 SOW 600 V	ADB Airfield Solutions	Supplied with sign	B
3	12 x 24 in. (304.8 x 609.6 mm) L-867B base	ADB Airfield Solutions	2124	C
7	Flexible conduit	Contractor	Not applicable	A
10	Frangible coupling	ADB Airfield Solutions	62A0711	C
11	2 in. (50.8 mm) L-867 base plate	ADB Airfield Solutions	1932	C

NOTE A: Refer to Table 3-3 for flexible conduit connectors.

NOTE B: Signs supplied with the following length external to the sign: Size 1 = 47 in. Size 2 = 41 in. Size 3 = 35 in. Size 4 = 18 in. Size 5 = 35 in. Any other external length requires a separate line on the purchase order specifying the external length required.

NOTE C: Requires a separate line item on purchase order.

NOTE D: Shown for reference only. Part supplied with sign.

Table 3-3 Flexible Conduit Connectors

Item	Description	Supplier
4	3/4-inch (44.45 mm) diameter hole	ADB Airfield Solutions
6	1-1/4 inch (31.75 mm) flexible conduit male connector	Contractor
7	1-1/4 inch (31.75 mm) flexible conduit	Contractor
8	1-1/4 inch (31.75 mm) flexible conduit male connector	Contractor
9	1-1/2 x 1-1/4-in. (38.1 x 31.75-mm) hex reducer bushing	Contractor

Cord set Exit Location #3

Figure 3-3 shows cord set location #3. Refer to Table 3-4 for cord set location #3 parts and part numbers.

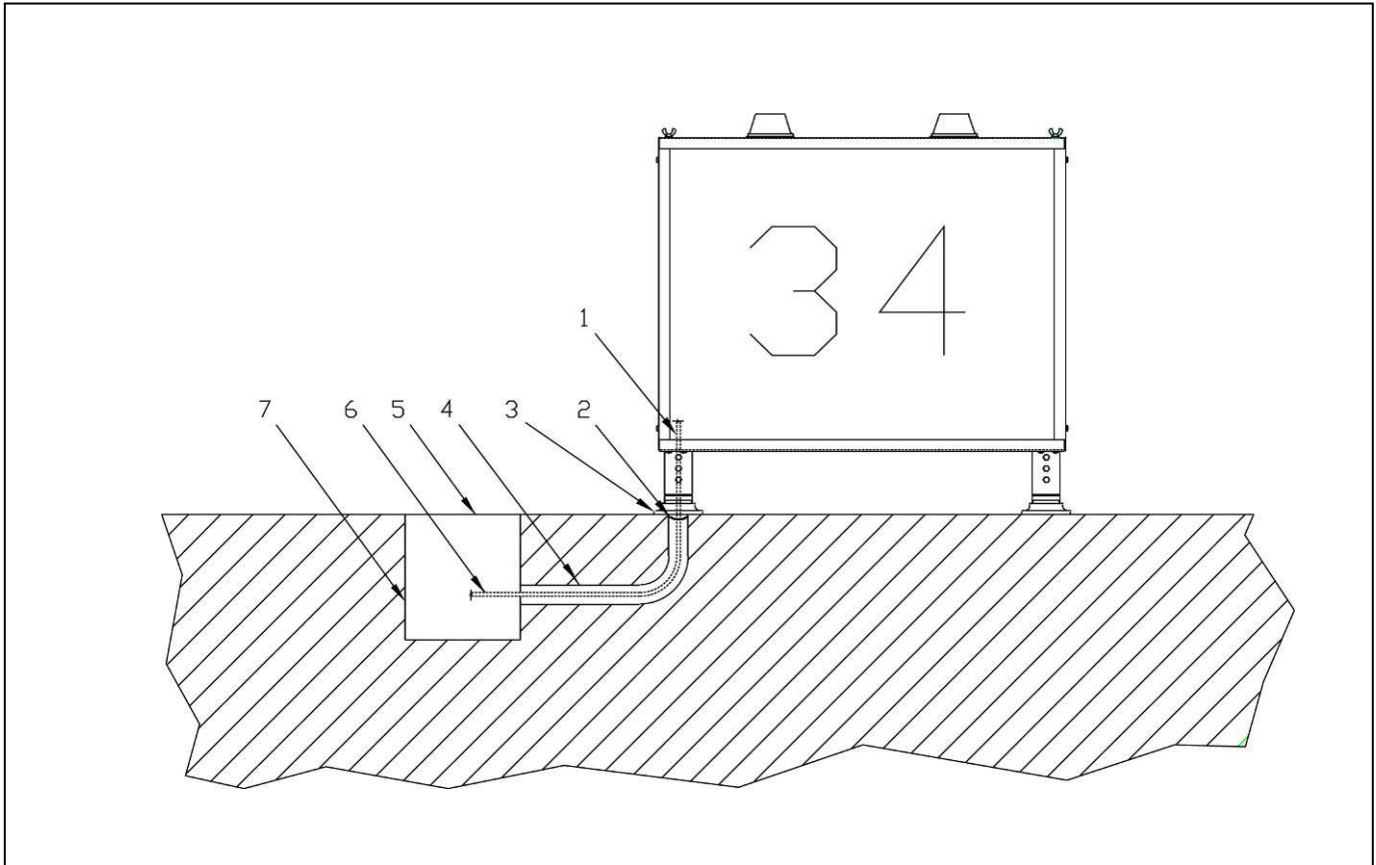

Figure 3-3 Cord set Location #3 (Standard)

Table 3-4 Cord set Location #3 Parts

Item	Description	Supplier	Part Number	Note
1	Cord set 16/2 SOW 600 V	ADB Airfield Solutions	Not applicable	
2	Cable clamp	ADB Airfield Solutions	60A2851	B
3	Base flange	ADB Airfield Solutions	62A2142 or 62A2146	A
4	2-in. (50.8 mm) rigid conduit	ADB Airfield Solutions	Not applicable	
5	3/8 inch (9.53 mm) thick base plate	ADB Airfield Solutions	1000-6	
6	8-foot (2.44 m) extension cord	ADB Airfield Solutions	73A0109-8	C
7	12 x 24 in. (304.8 x 609.6 mm) L-867B base	ADB Airfield Solutions	2124	C
NS	Gasket	ADB Airfield Solutions	2052	B, D

NOTE A: Shown for reference only. Part supplied with sign.

NOTE B: Requires a separate line item on purchase order.

NOTE C: Refer to *Cord sets and Extension Cords* in this section for extension cords available if different extension cord length is required.

NOTE D: Gasket is sold separately.

Cord set Exit Location #4

Figure 3-4 shows cord set location #4. Refer to Table 3-5 for cord set location #4 parts and part numbers.

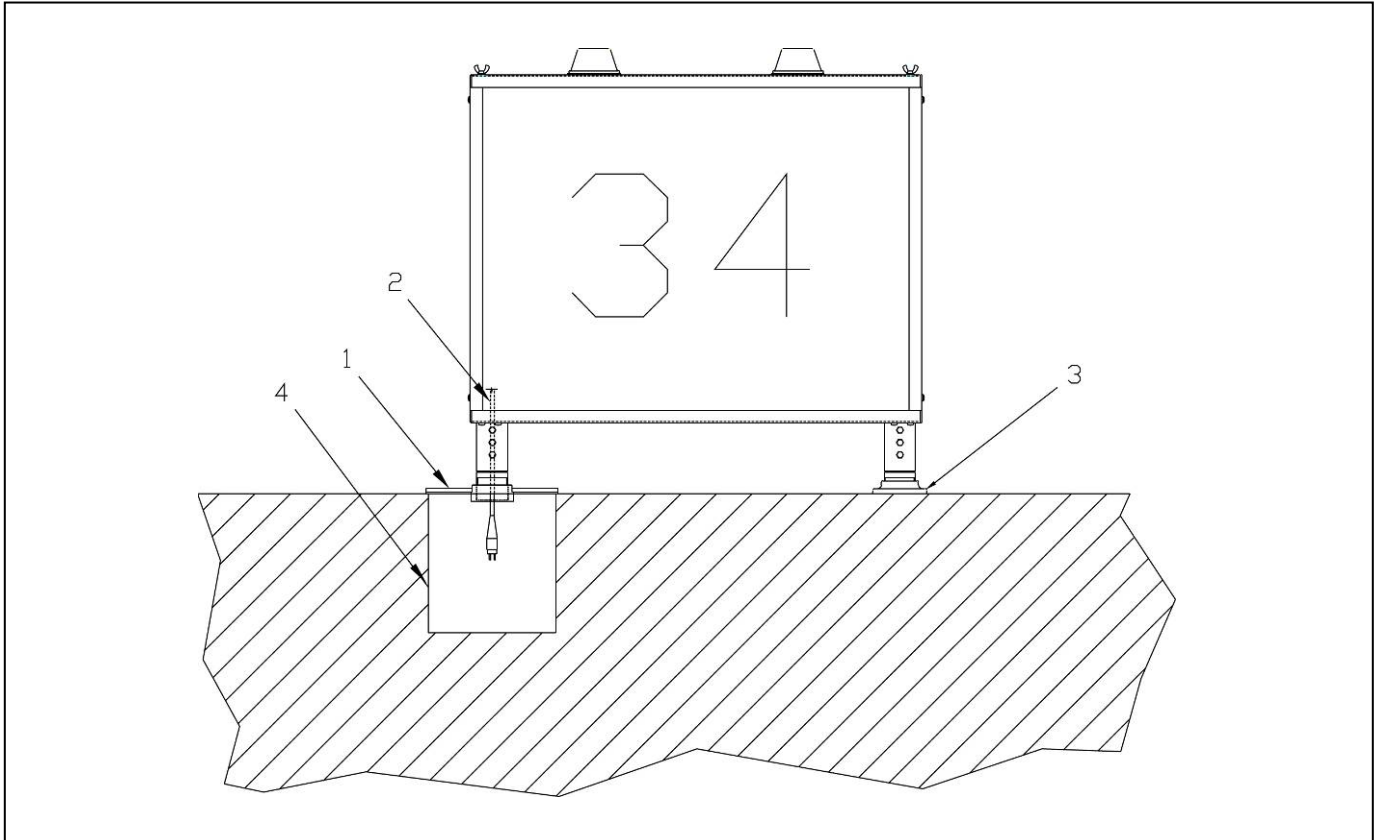

Figure 3-4 Cord set Location #4 (Standard)

Table 3-5 Cord set Location #4 Parts

Item	Description	Supplier	Part Number	Note
1	12-inch heavy base plate, 2-1/2 NPT	ADB Airfield Solutions	1832-BSPLT	B
2	Cord set 16/2 SOW 600 V	ADB Airfield Solutions	73A0107/72	A
3	Base flange	ADB Airfield Solutions	62A2142 or 62A2146	A, C
4	12 x 24 in. (304 x 610 mm) L-867B base	ADB Airfield Solutions	2124	B

NOTE A: Shown for reference only. Part supplied with sign.

NOTE B: Requires a separate line item on the purchase order.

NOTE C: Remove the base flange shipped with the sign when the leg is screwed into the base plate.

Cord set and Extension Cords

See Figure 3-5. Refer to Table 3-5 for cord set and extension cord types. Refer to Table 3-7 for cord set and cord parts.

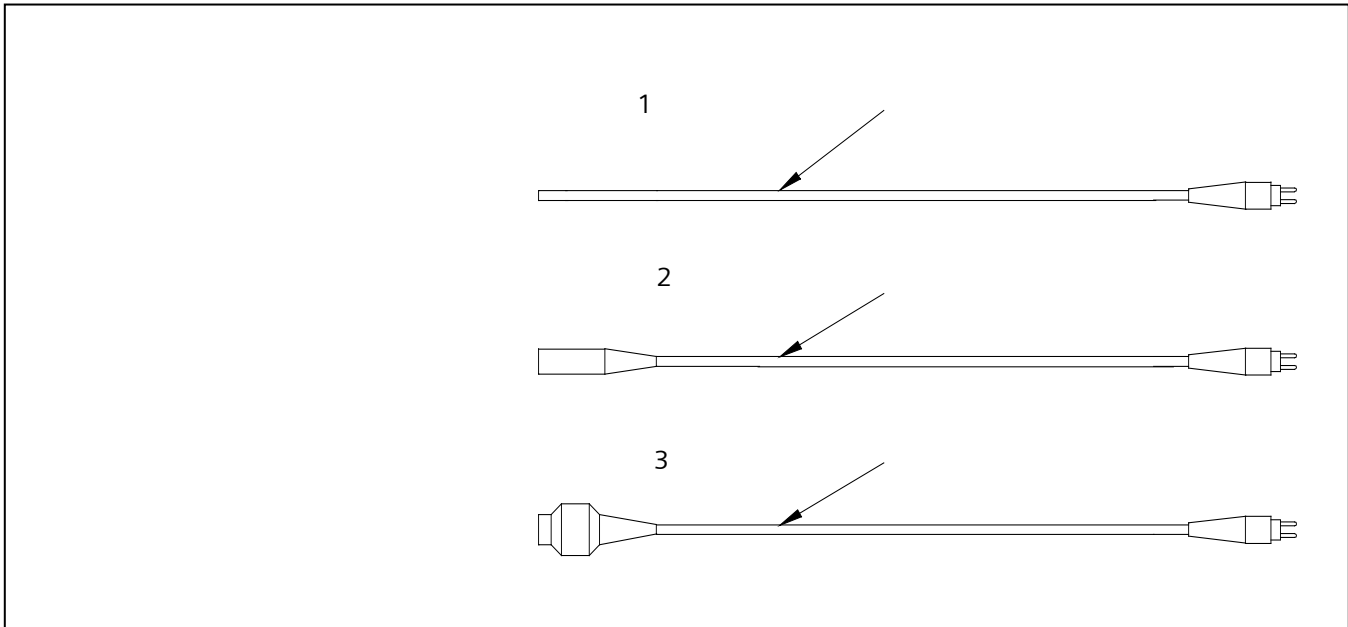

Figure 3-5 L-823 Cord set and Extension Cords

Table 3-6 Cord set and Extension Cord Length

Type	Part Number	Receptacle Style	Plug Style	Standard Length	Wire
1	73A0107-X	Not applicable	Type II, Class A, Style 1	4 ft (1.22 mm) 6 ft (1.83 mm)	16/2
2	73A0108-X	Type II, Class A, Style 7	Type II, Class A, Style 1	8 ft (2.44 mm)	16/2
3	73A0109-X	Type II, Class A, Style 7	Type II, Class A, Style 1	8 ft (2.44 mm)	16/2

Table 3-7 Cord set and Extension Cord Parts

Item	Description	Part Number	Note
1	L-823 cord set, 16/2 wire Cord set, standard size 4 ft (1.22 mm) Cord set, standard size 6 ft (1.83 mm)	73A0107-48 73A0107-72	A, B
2	L-823 cord set extension cord, 16/2 wire, standard size 8 ft (2.44 mm)	73A0108-8	A, C
3	L-823 cord set extension cord, 16/2 wire, standard size 8 ft (2.44 mm)	73A0109-8	A, D

NOTE A: Other sizes require special order.

NOTE B: A minimum of thirty inches (762 mm) of cord set length is required for internal sign connections. Usable exterior cord set length is equal to the cord set length minus a minimum of 30 inches (varies with sign size and cord set exit location).

NOTE C: Receptacle may be connected to plug on 73A0107-X, 73A0109-8 cord set, or standard 31-inch (787.4 mm) L-823 cord set.

NOTE D: Receptacle must be connected to plug on, Plug Type II, Class A, and Style 1, supplied with the sign.

4. Installation



WARNING: Signs must be grounded to a true earth ground. Failure to observe this warning may result in personal injury, death, or equipment damage.

General Guidelines

When installing signs, follow the guidelines below

- **See FAA AC 150/5340-30, Fig 126 for mounting pad design.** Also see the following subsections for detailed information on sign pad and leveling of the sign.

FAILURE TO INSTALL AND LEVEL THE SIGN AS DESCRIBED IN THE VARIOUS SUBSECTIONS BELOW WILL VOID THE WARRANTY

- Mount the signs on a concrete slab or concrete pedestals
- Do not allow concrete edges to protrude above grade.
- Provide power to the signs through breakaway cable connectors installed within the frangible coupling portion of the sign's mounting legs.
- Install auxiliary equipment, such as isolation transformers, in a light base embedded in the ground.

Overall Mounting Height

Install signs so that the overall height above the surrounding ground of the sign assembly, including mounting supports, does not exceed heights given in Table 2-6 and the clearances of aircraft wings as specified in AC 150/5340-18. The sign must provide 12 inches (304.8 mm) of clearance between the top of the sign and any part of the most critical aircraft using, or expected to use, the airport when the aircraft's wheels are at the pavement edge. For overall mounting height, refer to AC 150/5345-44.

Sign Orientation

When orienting signs follow the guidelines below

- Orient the sign so that the face is perpendicular to the centerline of the taxiway or runway.

NOTE: Check site plans and specifications for the location of the power leg (leg where the L-823 cord set is located) in reference to the L-867 light base. Typically, the L-867 light base is immediately under the power leg or is at the same end, but not under the power leg. ADB Airfield Solutions' signs are shipped with the sign product label attached to the sign end where the power leg is located. In addition, verify that the sign legend is orientated correctly to the taxiway or runway per the site plans when the sign is installed on the pad. If the sign legend location is not correct, then the panels must be removed and reinstalled in the sign in the correct location.

- For special situations where visibility would be improved, can't single-sided signs. Refer to FAA AC 150/5340-18 for the correct orientation.
- For signs identifying an instrument landing system (ILS) critical area, coordinate the location and orientation with the local FAA airway facilities personnel, and schedule installation with periodic ILS flight checks to ensure that signs do not cause interference with the ILS electronic signal.

Sign Distance from Pavement Edge

Refer to Table 3-8 for the distance of signs from the pavement edge. Refer to AC 150/5340-18 for more information on the location of different types of taxiway signs.

Table 3-8 Recommended Sign Distance from Pavement Edge

Sign Size	Distance from Pavement ft	Distance from Pavement m
1	10–20	3.1–6.1
2	25–35	7.6–10.7
3	35–60	10.7–18.2
4	50–75	15.2–22.9
5	20–35	6.1–10.7

Sign Installation on Concrete Pad

NOTE: Follow site plans and specifications for concrete dimensions.

Concrete Pouring

See FAA AC 150/5340-30, Figure 126, for concrete base design.

To pour a concrete pad, perform the following procedure:

1. Determine the sign size and module.
2. Pour your concrete pad according to the following requirements:
 - a minimum of 30 inches (762 mm) wide, extending a minimum of 6 inches (152.4 mm) beyond the end of the supports. The sign pad needs to be flat and level in the area where the sign mounting flanges are located. See FAA AC 150/5345-30, Figure 126. The mounting floor flange is nominally 5.0 wd x 7.50 lg and the area beyond the flange can be tapered to the outside edge of the concrete pad to provide for pad drainage.
 - a minimum of 4 inches (101.6 mm) depth, extending below the frost line to prevent frost heave
 - reinforce according to site plans and specifications

Sign Installation on Concrete Pad *(cont)*

3. Install a minimum of one 12-inch (304.8 mm) L-867B power base (1) according to the following guidelines:
 - Install the base close to the sign in or near the concrete pad to provide easy access to the isolation transformer.
 - When installing the base in the concrete pad, hold the L-867 base firmly in place during construction of the pad so that the upper surface of the base flange is level within ± 2 degrees and not more than 3/8 inch (9.525 mm) above the concrete surface.
 - All other bearing surfaces on the pad for additional flange supports should be kept in the same horizontal plane as the L-867 base flange. The pad area where the sign mounting flanges will be located is to be flat **with no taper** to ensure that the sign will set level to prevent uneven loading on the frangible couplings. See FAA AC 150/5340-30, Figure 126 for pad design.
 - **For the Mode 1 and 2 signs**



Before the concrete sets, install two 1/2–13 anchor bolts into the concrete pad. The bolt hole centerline is on a 6-inch diameter bolt circle, 180 degrees apart as shown. Bolt slots are .62 wd x 1.0 lg. Overall width of flange is 5.0 inches and overall length is 7.5 inches. Bolts should be located perpendicular to the sign face

Figure 3-6 Mode 1 and 2 Frangible Couplings

- **For the Mode 3**

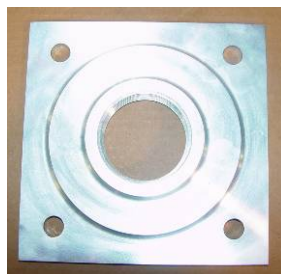

Before the concrete sets, install four 1/2–13 anchor bolts into the concrete pad. The bolt holes are on an 8-inch-diameter bolt circle, 90 degrees apart as shown. Holes are .62 diameter. Overall size is 7.75 x 7.75 inches. Bolts should be located perpendicular to the sign face.

Figure 3-7 Mode 3 Frangible Couplings

NOTE: A customer-supplied setting fixture is recommended to hold the bolts in position while the concrete sets.

NOTE: Anchor bolts must be a minimum of 1.25 inches (31.75 mm) above the top surface of the concrete pad to attach the mounting bases. Hilti quick bolts are recommended for installing the flanges after the concrete sets.

Sign Mounting

NOTE: Signs up to four modules are totally assembled at the factory and are ready for direct installation. Mounting flanges may be removed to lubricate the threads of the frangible coupling with anti-seize compound before installing sign.

NOTE: If male L-823 connector is routed through a leg, slide frangible coupling over male connector and insert into female connector in base plate, and then screw frangible coupling into base plate.

To mount the sign onto the concrete pad to insure the assembly is flat, perform the following procedure:

1. When the sign is ready to be bolted to the concrete pad set the sign assembly on the concrete pad and position the sign over the anchor bolts. Hand-tighten the bolts or nuts to fasten the mounting flanges to the concrete pad.
2. **To insure that the sign assembly is mounted flat on the concrete pad,** first loosen all three hex set screws found on each frangible coupling that are installed on the sign. See Fig 3-8 on page 3-11. Once all the hex screws are loosened each of the sign legs will float free inside the frangible coupling that is screwed into the mounting flange. Second, use a bubble, digital, or laser level to verify that the assembly is flat and level. Adjustments to make the assembly flat and level can be made by raising or lowering one end of the sign assembly to make the assembly flat and level.

NOTE: Once the assembly is flat it may be necessary to block-up or hold the assembly in the flat position until all of the hex set screws can be re-tightened on each of the frangible couplings to secure the sign leg to the coupling. Once the sign is flat and level finish tightening the mounting bolts to their correct torque value.

NOTE: If the sign pad is tapered in the area when the mounting flanges are located shims may need to be placed under the mounting flanges to ensure that the coupling frangibility characteristics are the same for each coupling. If in doubt, contact ADB Airfield Solutions Engineering.

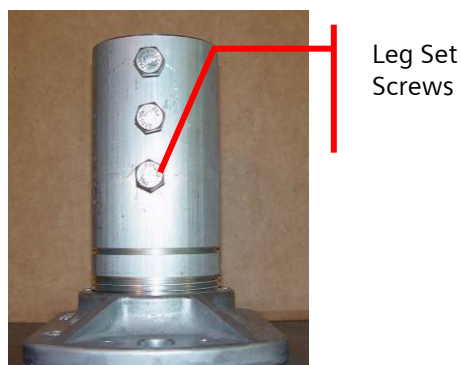

Figure 3-8 Sign Frangible Coupling

Sign Mounting (*cont*)

CAUTION: Sign frangible couplings are uniquely designed for use on the sign size stamped on the coupling and can only be used for that particular size sign. If couplings must be replaced, make sure the sign size on the couplings matches the size sign on which they are to be installed.

3. Connect an AWG 12 (minimum) ground wire to the earth ground lug on the bottom of the sign. Refer to *Wiring* in this section. Refer to the *Wiring Schematics* section for electrical connections for series circuit and parallel circuit installation.



WARNING: Lock out power before making any electrical connections. Failure to observe this warning may result in personal injury, death, or equipment damage.

4. Install optional tether. Refer to *Optional Tethers* in this section.
5. Plug the cord set into the sign and the transformer.
6. Reinstall panels (if removed) and top lid (if removed). Refer to the *Repair* section for more information on installing the lid.

Optional Lamps-Out Indicator Mounting

See Figure 3-9. Signs with optional Lamps-Out Indicator (LOI) are factory-installed and shipped with an LED mounted in both sides of the sign. Only one LOI LED works at a time. The LOI LED comes wired and is set at medium intensity. The LOI can be used only on halogen lamp Style 2 and Style 3 signs.

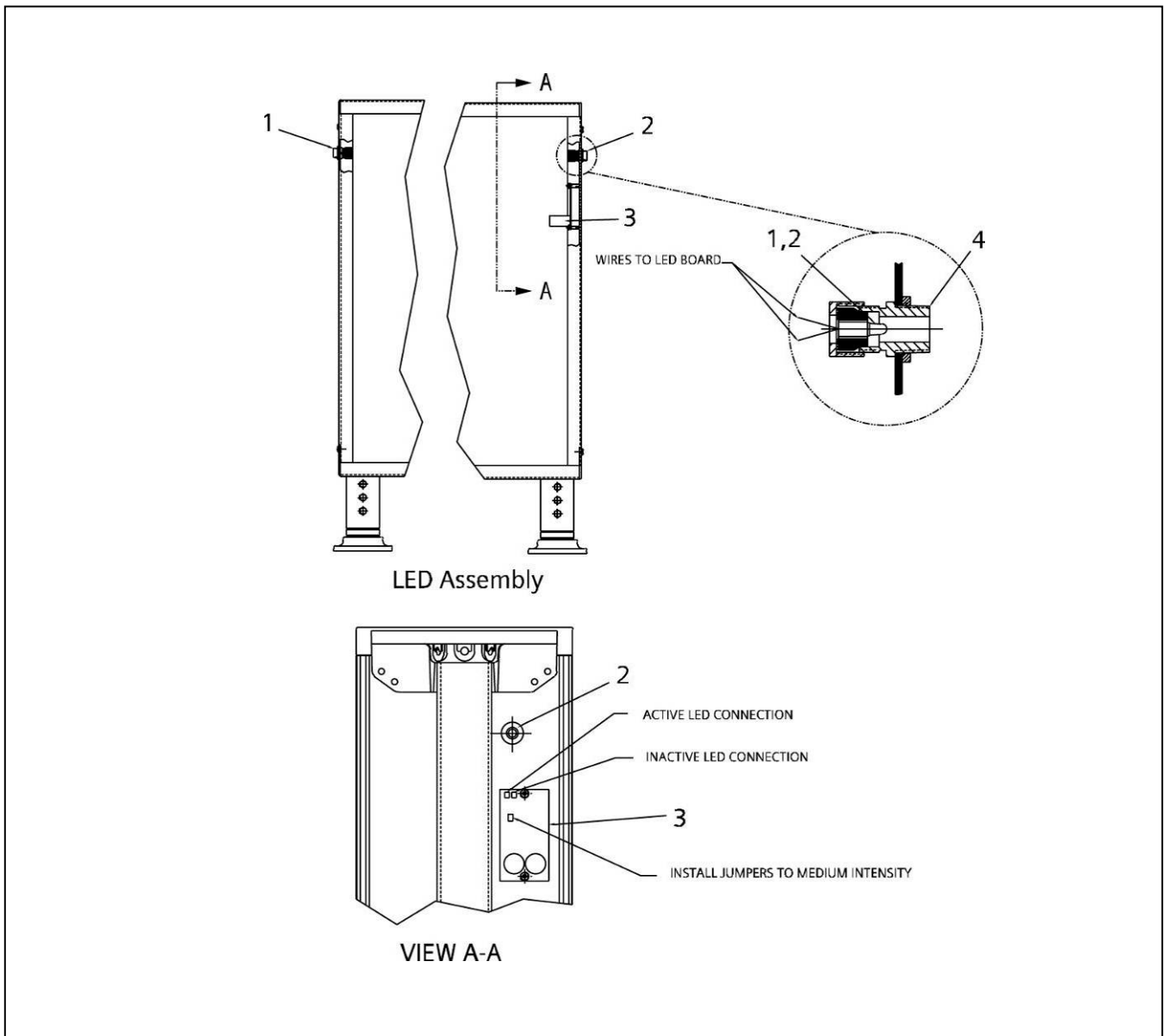

Figure 3-9 Lamps-Out Indicator Kit Assembly

- | | |
|---|----------------------------------|
| 1. Lamps-Out Indicator LED Assembly, (190 Inch-Leads) | 3. LED Lamps-Out Indicator PCB |
| 2. Lamps-Out Indicator LED Assembly, (10 Inch-Leads) | 4. 1/2-Inch Watertight Connector |

Optional Lamps-Out Indicator Mounting (cont)

See Figures 3-9 and 3-10. Once the sign is installed, it is possible to change the LED intensity and the side of the sign in which the LED is activated. To determine which LED to make active, open the sign and plug the desired LED connector onto the ACTIVE header on the LOI PCB.

The LOI LED intensity level (Low, Medium, and High) can be changed by opening the sign and moving the intensity jumper shunt on the LOI PCB to the desired level.

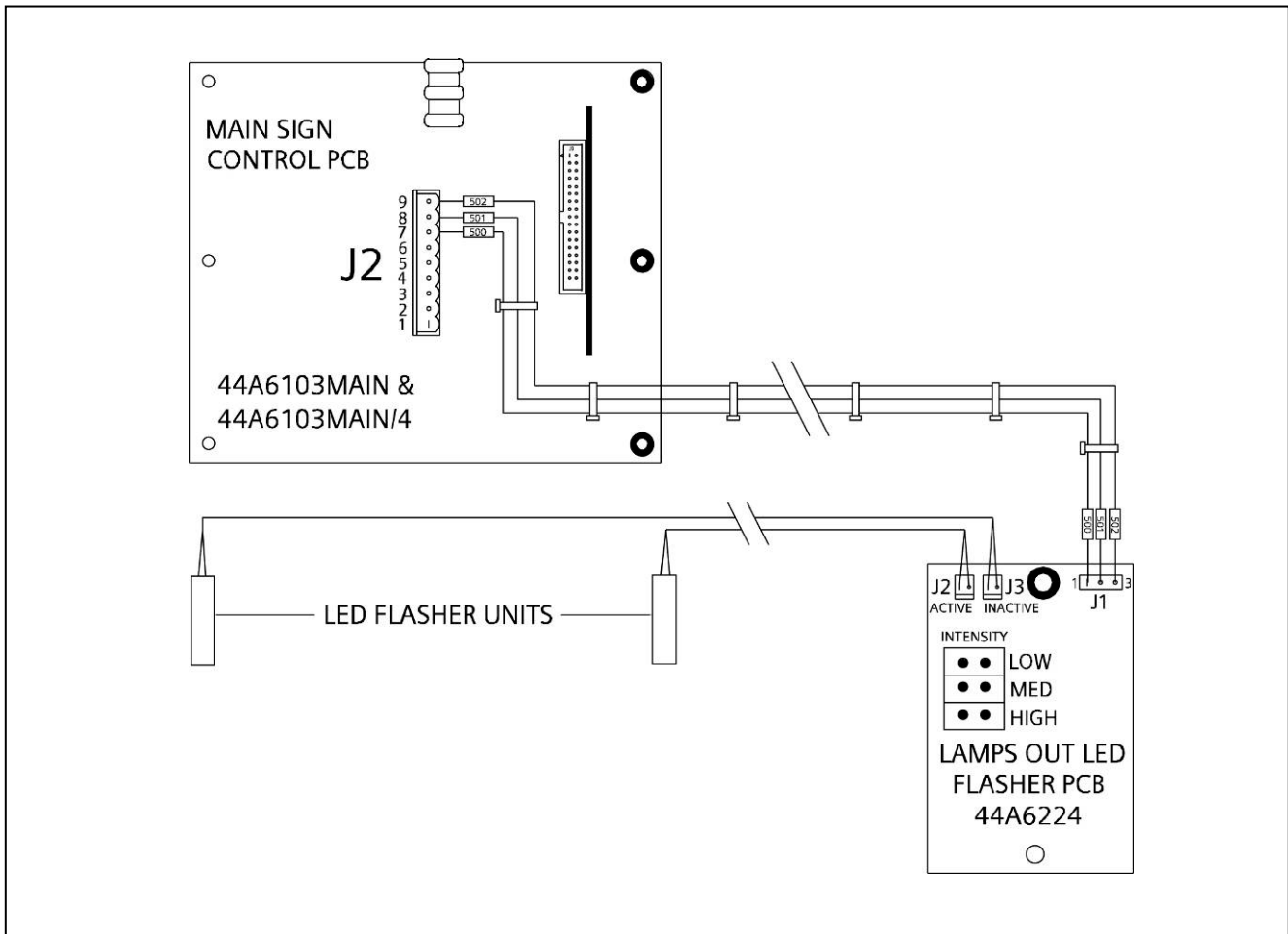

Figure 3-10 Lamps-Out Indicator Wiring

Wiring

Refer to the *Wiring Schematics* section for wiring diagrams.

When installing cable, follow the guidelines below.

- Install all cable for direct earth burial or for placement in duct according to Item 108 or Item 110 of AC 150/5370-10 as appropriate.
- Operate the signs as a part of a series 6.6 A (or 20 A) lighting system power supply. The signs are connected into the series circuit by means of an internal 5.5 A-6.2 A step-up isolation transformer for Style 5, Sizes 1, 3, 4, and 5 signs, or a 5.5 A-6.0 A step-up isolation transformer for Style 5, Size 2 sign. If installation is to be independent of other lighting circuits, use current edition of AC 150/5340-24, *Runway and Taxiway Edge Lighting System*, for system reference and material needs.

Earth Ground Lug



WARNING: Signs must be properly grounded to true earth ground. Failure to observe this warning may result in personal injury, death, or equipment damage.

Attach the earth ground lug. The earth ground lug is located on the outside frame of the sign to permit easy connection of an AWG 12 (minimum) earth ground wire to the sign. If necessary, you may remove the ground lug from the outside and place it on the inside.

Optional Tethers

See Figure 3-12. Tethers are shipped installed on the sign sales order. Location and quantity of the tether are determined when the sales order is placed.

NOTE: In the tether installation procedure below, the customer supplies the mounting hardware to attach one end of the tether to the concrete pad. The customer also supplies the expansion anchor for the bolt.

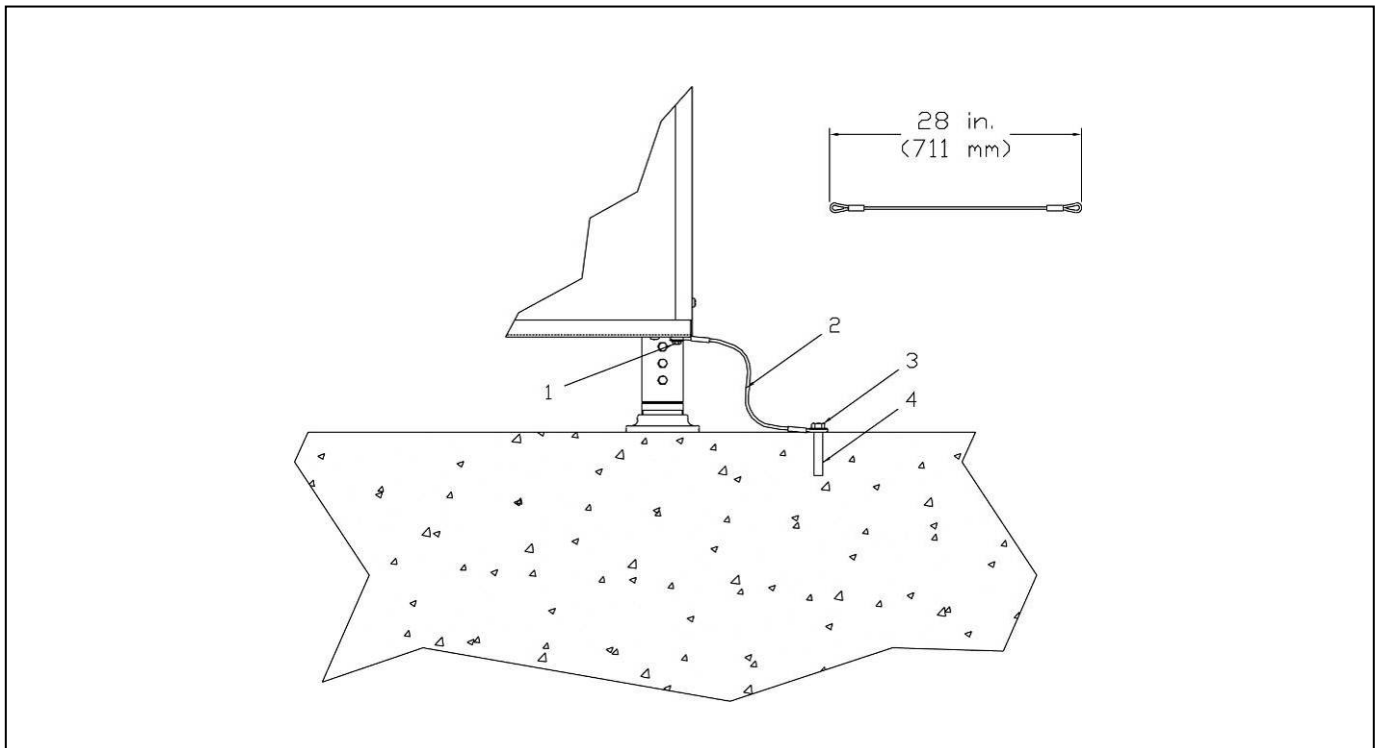

Figure 3-11 Installing Optional Tether

1. Existing 5/16-18 x 3/4 in. Bolt
2. Tether
3. Mounting Hardware Attached to Expansion Anchor
4. Expansion Anchor for Bolt

To attach a tether, install the customer-supplied mounting hardware (3) to attach the tether to the expansion anchor (4) on the concrete pad.

Optional L-830 Series Wiring

The following discussion applies only to a 4-module sign, Size 2 and Size 3.

When a multiple-module sign installation requires a 500 W isolation transformer, you may use two lower-wattage L-830s instead if they are series-wired and provided the total wattage of the transformers equals the wattage of the transformer they are replacing. For example, you can replace the 500 W transformer with two series-wired 300 W and 200 W L-830 transformers.

If your sign installation results in two cord sets exiting a sign cord set, you can eliminate one cord set by series wiring the L-830s and connecting the primary 3- or 5-Step sign transformer leads in series as required for single cord set installations.



NOTE: On occasion, the windings in the L830 Isolation Transformers may be wired differently. The result will be that the output voltage on the secondary of the isolation transformer will be out of phase when the two transformers are in series. This condition will result in improper operation of the sign. This situation is resolved by replacing the field splice kit on one of the transformer's secondary and reversing the wires.

Optional L-830 Series Wiring (*cont*)

Refer to Table 3-9 for parts for the L-830 series wiring kit. See Figure 3-9.

Table 3-9 L-830 Series Wiring Kit

Item	Description	Part Number	Quantity
1	L-830 series wire kit	94A0173	1
2	Style 11 receptacle kit	70A0046	1
3	Jumper wire	89A0154	6 feet
4	Style 4 plug kit	70A0045	2

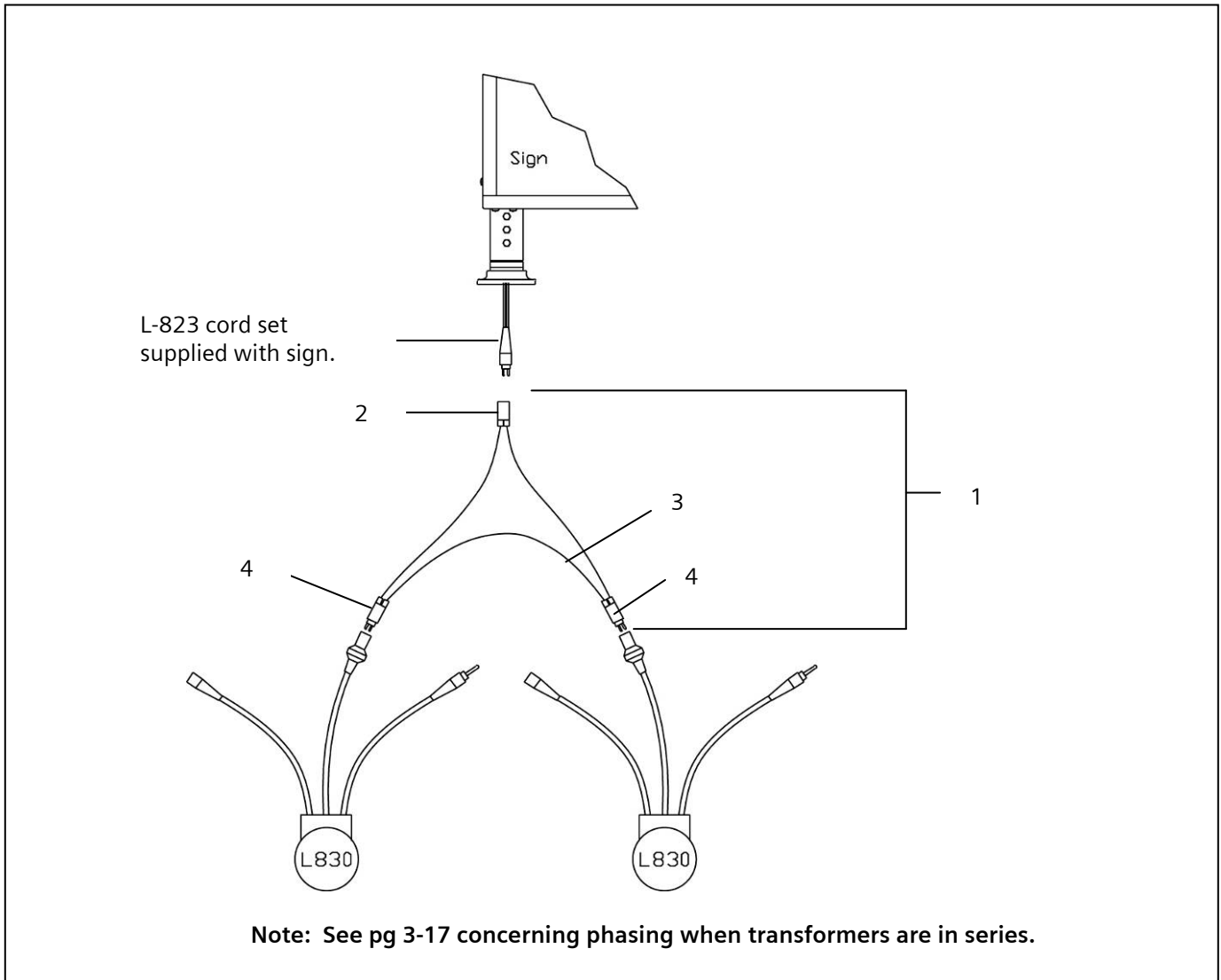

Figure 3-12 Installing Optional L-830 Series Wiring

Section 4

Maintenance

1. Introduction

This section provides preventive maintenance for L-858 signs.

2. Maintenance Schedule

To keep the L-858 taxiway and runway signs operating efficiently, follow a preventive maintenance schedule. Refer to Table 4-1.

Table 4-1 L-858 Taxiway and Runway Sign Maintenance

Interval	Maintenance Task	Action
Daily	Check for burned-out lamps.	Replace burned-out lamps. Check circuit operation.
Monthly	Check for dirty panels. Check for vegetation covering panel.	Clean with mild soap and water. Remove vegetation.
Semi-Annually	Check for loose wire connections. Check for cracked or deteriorated wire.	Tighten wires. Replace wire.
Annually	Check for paint flaking off. Check for panels yellowing. Check for deteriorated gaskets.	Repaint. Clean with Formula 409 or similar cleaning agent. Replace gaskets.

Section 5

Troubleshooting



WARNING: Allow only qualified personnel to perform the following tasks. Observe and follow the safety instructions in this document and all other related documentation.



WARNING: Always remove input power to a sign before making any wiring connections. Failure to observe this warning may result in personal injury, death, or equipment damage.

1. Introduction

This section provides troubleshooting information for the L-858 taxiway and runway signs. The information covers only the most common problems. If you cannot solve the problem with the information given here, contact your local ADB Airfield Solutions representative for help.

2. Troubleshooting Procedures

Problem – Halogen & Fluorescent	Possible Cause	Corrective Action
1. All lamps are out or not functioning correctly.	Loose wires or connections	Tighten or replace wires. Check L830 for out of phase condition – see page 3-17
	Lamp(s) burned out	Replace lamp(s). Refer to <i>Lamp Replacement</i> in the <i>Repair</i> section.
	CCR circuit-shortcd	NOTE: If burned-out lamp is near maximum lamp-hour, it is recommended that you replace all lamps. Check circuit. Refer to AC 150/5340-26.
	Ballast Power Supply Failed	Verify output of supply measures 200 to 250Vdc
	Active ballast, associated bridge rectifier module or Standard VA transformer failed	Replace active ballast assembly, associated bridge rectifier module or Standard VA transformer and check for burned out lamps. Replace lamps, as required. Refer to <i>Lamp Replacement</i> and <i>Active Ballast Assembly Replacement</i> in the <i>Repair</i> section. Refer to <i>Active Ballast Assembly Connections</i> in this section.
2. Zero cross fault LED is on.	50 Hz/60 Hz jumper in wrong position	Move the jumper to the correct position. Refer to <i>Jumper Settings</i> in this section.

Continued on next page

2. Troubleshooting Procedures *(cont)*

Problem - Halogen Only	Possible Cause	Corrective Action
3. Fault LED is on or cannot adjust lamp current to 6.2 A.	Isolation transformer saturating	Replace isolation transformer with one of sufficient capacity. Refer to Tables 2-14 through 2-16 in Section 2, <i>Description</i> , to locate the appropriate isolation transformer. Refer to <i>Active Ballast Assembly LEDs</i> in this section. NOTE: If the Fault LED comes on while using the 2.8A step of the regulator, then check the lamp current. If the lamp current dropped only 1/10 of an amp, then the isolation transformer does not need to be replaced.
	Active ballast assembly failed	Replace active ballast assembly. Refer to <i>Active Ballast Assembly Connections</i> in this section. Refer to <i>Active Ballast Assembly Replacement</i> in the <i>Repair</i> section.
4. Monitor LED is on	Lamp burned out	Replace burned out lamp. Refer to <i>Lamp Replacement</i> in the <i>Repair</i> section.
	Backup lamps present jumper in wrong position	Move the jumper to the correct position. Refer to <i>Jumper Settings</i> in this section.
5. Lamps are flashing.	Not enough load on LC (SCR type) CCR	Increase the load on the SCR type regulator, use a smaller SCR type regulator, or use a ferroresonant regulator.
6. Lamps-Out Indicator LED not flashing when lamp is out	Lamps-Out Indicator LED wiring and connectors not installed properly	Verify that wiring and connectors are installed properly.
	Lamps-Out Indicator PCB not having sufficient time to charge	Verify that the intensity jumper is installed correctly. Verify that the LED is plugged into the active connector on the Lamps-Out Indicator PCB. Allow the sign to run with backup lamps for approximately 6 hours.
	Lamps-Out Indicator PCB failure	Replace Lamps-Out Indicator PCB.
7. Lamps-Out Indicator LED not bright enough	Lamps-Out Indicator PCB intensity level not high enough	Select higher intensity on Lamps-Out Indicator PCB.
	LED obstructed	Verify that nothing is obstructing the LED.

Continued on next page

2. Troubleshooting Procedures *(cont)*

Problem - Halogen Only	Possible Cause	Corrective Action
8. Lamps-Out Indicator LED remains flashing	Power on sign not cycled	Cycle power on the sign.
	More bulbs burned out on sign	Verify that no more bulbs are burned out in the sign.

Problem –Fluorescent Only	Possible Cause	Corrective Action
9. All or some lamps out	Lamp failure	Replace lamp(s)
10. All lamps out	Ballast not powered	Check ballast input for 200-250Vdc. If not present, replace DC power supply PCB, verify proper current is input into the DC power supply PCB, or check wiring Turn sign input power off for 3 minutes and then turn input power back on to sign. If lamps still do no light replace ballast. NOTE: If ballasts are manufactured by Vosslo-Schwabe contact ADB Airfield Solutions.
	Ballast failure or ballast in self-protect mode	
10. All lamps out	Transformer is undersized	Replace isolation transformer with next higher size
	Power supply failed	Disconnect ballast(s) from the power supply and make sure output is 200-250Vdc. If the voltage is not in this range then replace the power supply.

3. Jumper Settings

See Figure 5-1. Refer to Table 5-1 for the appropriate jumper settings on the 44A6225 Active Ballast.

Table 5-1 Jumper Settings

Jumper	Setting
50 Hz/60 Hz	Set to the power line frequency.
Backup lamps present	Set to Yes if backup lamps are installed.

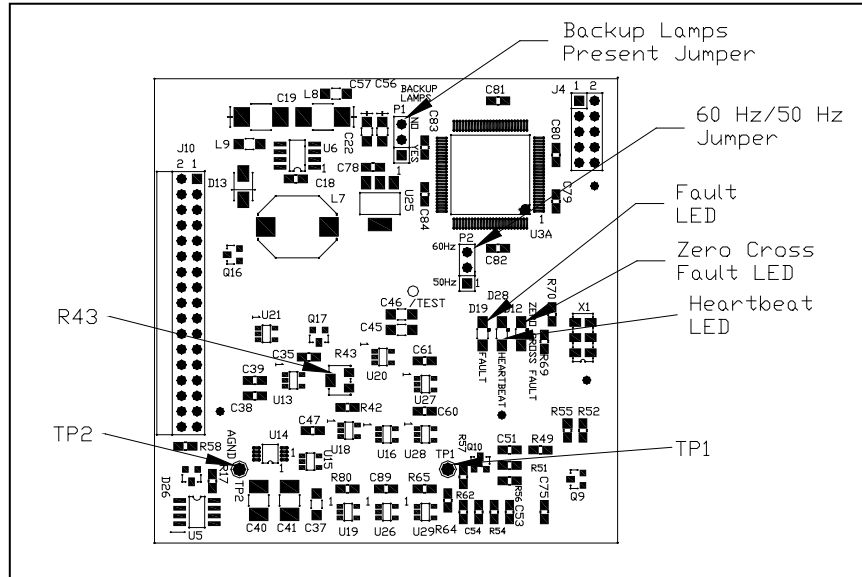

Figure 5-1 Active Ballast Assembly

4. Lamp Current Adjustment Procedure – Low and Standard VA

This subsection provides the lamp current adjustment procedure to increase or decrease the lamp brightness level.

For the Low VA sign perform the following procedure:

NOTE: You CANNOT obtain true lamp current readings by measuring current at the lamp. Current readings must be taken using test points T1 & T2 on the Active Ballast board. **DO NOT USE AMMETER.** All readings must be taken as follows:

1. See Figure 5-1. Connect a voltmeter to TP1 and TP2. The voltmeter will read 100mV dc per one Amp of lamp current.
2. Adjust potentiometer R43 for the desired lamp current. R43 is preset at the factory to 6.2 A (620mV dc from TP1 to TP2).

For the 3-5 Step, Standard VA signs perform the following procedure:

Brightness-Control Transformers

NOTE: ADB Airfield Solutions has set the tap on the 3- and 5-step transformers at the nominal position at the factory. You should normally not have to adjust these transformers.

Brightness-Control Transformers (*contd.*)

Three- and five-step brightness control transformers are installed in the L-858 sign

- to meet illumination requirements.
- to operate in series circuit lighting systems to maintain the current at the standards referred to in Table 5-1. This provides the most ideal brightness for the signs and extends lamp life.

NOTE: Refer to the *Wiring Schematics* section for 3-Step module and 5-Step module wiring schematics.

Table 5-1. Transformer Brightness Control Standards

Transformer	Lamp Current Range (Amperes)	Primary Range (Amperes)
3-Step	5.7–6.4	4.8–6.6
5-Step	5.4–6.4	2.8–6.6

Brightness-Control Procedures

This subsection provides brightness level and lamp brightness adjustment procedures.

Brightness Level Adjustment

To adjust the brightness level of the 3- or 5-step series sign, perform the following procedure:

1. Use a true-RMS ammeter to check the lamp current.
2. Raise or lower the lamp current taps on the 3-step or 5-step transformer to increase (if the light is too dim) or decrease (if the light is too bright) the current to the lamps. Refer to *Lamp Brightness Adjustment (3-Step Transformer)*, *One- and Two-Lamp Brightness Adjustment (5-Step Transformer)*, and *Three- and Four-Lamp Brightness Adjustment (5-Step Transformer)* in this section.

Lamp Brightness Adjustment (3-Step Transformer)

To adjust the lamp brightness level for a 3-step transformer, perform the following procedure:

1. Set the regulator current to 4.8 A.
2. See Figure 5-1. Use a true-RMS ammeter to verify that the sign's lamp current is above 5.7 A. If the lamp current is not above 5.7 A, increase the current by moving the lamp output to taps that give a higher output current.

NOTE: For example, if the factory ships a two-module Size 2 sign, the lamp taps are factory set at BLU-ORN. If the lamp current measured is not above 5.7 A for a CCR output current of 4.8 A, move the lamp wires down from BLU-ORN. See Figure 5-1.

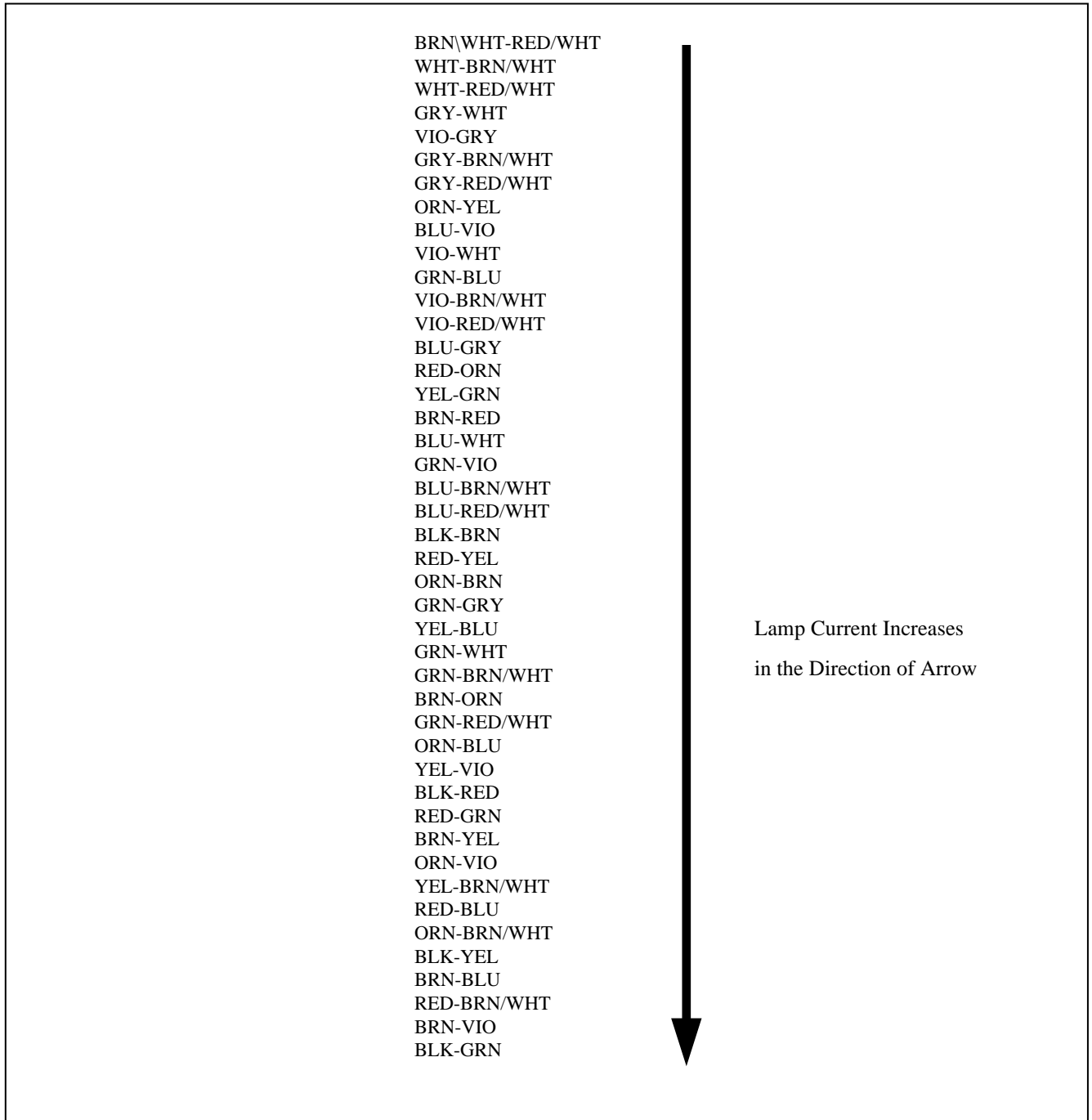

Figure 5-2-A Transformer Taps to change lamp current

Lamp Brightness Adjustment (3-Step Transformer) (contd.)

3. Set the regulator current to 6.6 A to ensure that the sign's lamp current is not above 6.4 A. If the lamp current is above 6.4 A, reduce the lamp current by moving the lamp output to taps in the opposite direction shown in Figure 5-1.

NOTE: For example, if the lamp current is over 6.4 A for a CCR current reading of 6.6 A, move the lamp output to taps up, as shown in Figure 5-1.

One- and Two-Lamp Brightness Adjustment (5-Step Transformer)

To adjust a one- and two-lamp brightness level for a 5-step transformer, perform the following procedure:

1. Set the regulator current to 2.8 A.
2. For one lamp, move the Primary tap from the One Lamp setting to the Two Lamp setting.
2. Use a true-RMS ammeter to verify that the sign's lamp current is above 5.5 A.
3. For two lamp system, there is no way to adjust the lamp current to make it higher.
4. To reduce the lamp current, move the Primary tap from the Two Lamp setting to the One Lamp setting.
3. Set the regulator current to 2.8 A.
4. Use a true-RMS ammeter to verify that the sign's lamp current is above 5.5 A.
5. Refer to Figure 5-1-A for further assistance.

Three Lamp Brightness Adjustment (5-Step Transformer)

To adjust a three- and four-lamp brightness level for a 5-step transformer, perform the following procedure:

1. See Figure 5-1-A. Set the regulator current to 2.8 A.
2. For three lamps, move the lamp output tap from the S3 setting to the S4 setting.
3. Use a true-RMS ammeter to verify that the sign's lamp current is above 5.5 A.
4. If the current is still not above 5.5A, move the Primary tap from the LC setting to the FR setting.
5. Use a true-RMS ammeter to verify that the sign's lamp current is above 5.5 A.

Four Lamp Brightness Adjustment (5-Step Transformer)

1. See Figure 5-1-A. Set the regulator current to 2.8 A.
2. For four lamps, move the Primary tap from the LC setting to the FR setting.
3. Use a true-RMS ammeter to verify that the sign's lamp current is above 5.5 A.
5. To reduce the lamp current, move the lamp output tap from the S4 setting to the S3 setting.
6. Use a true-RMS ammeter to verify that the sign's lamp current is above 5.5 A.
4. Refer to Figure 5-1-A for further assistance

**No-Step Series (Style 5)
And Fluorescent
Brightness Level Adjustment**

Brightness level cannot be adjusted.

5. Halogen Lamp Low VA (Active Ballast) Assembly LEDs

See Figures 5-1 and 5-2. Refer to Table 5-2 for the Low VA assembly LEDs.

Table 5-2 Low VA (Active Ballast) Assembly LEDs

LED	Function
Heartbeat	Flashes at 120 beats per minute when power is applied to the active ballast assembly
Fault	Indicates the active ballast assembly is not able to maintain a regulated lamp current
Zero cross fault	Indicates the active ballast assembly is not able to synchronize to the line frequency
Monitor	Indicates a lamp is burned out

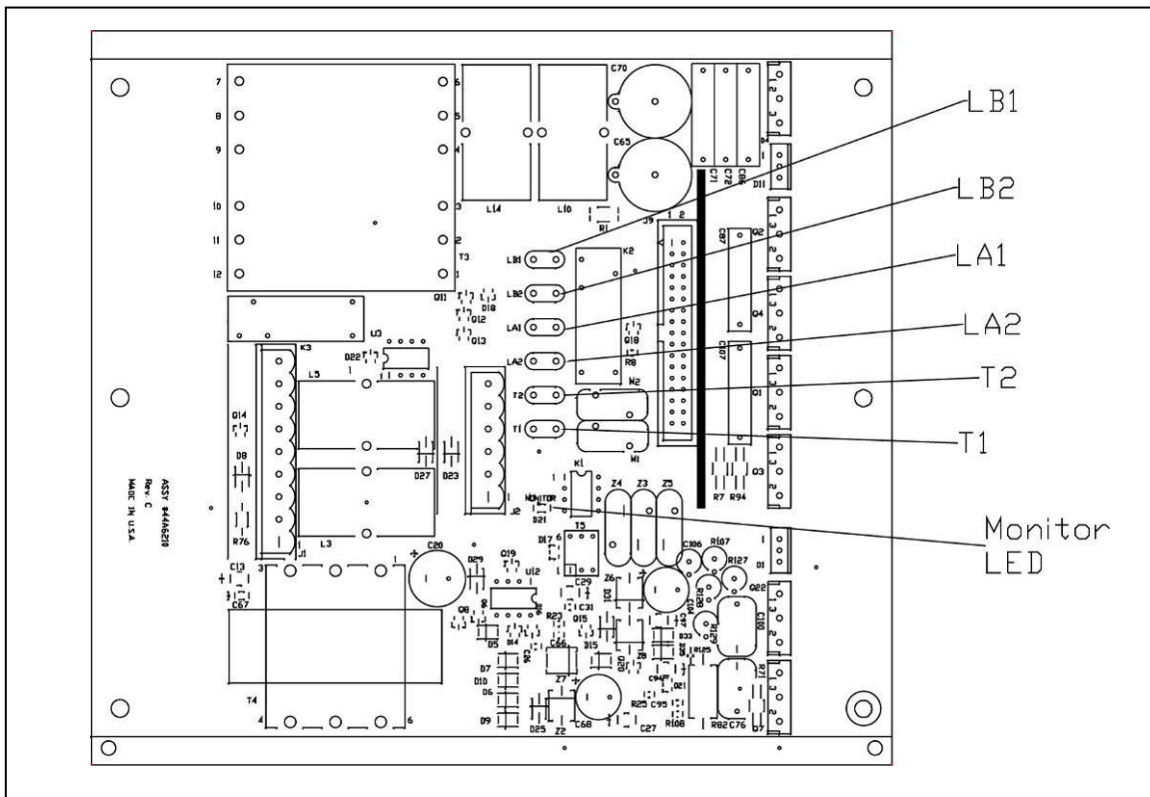

Figure 5-3 Low VA (Active Ballast) Assembly - Main Board

6. Halogen Lamp Low VA (Active Ballast) Assembly Connections

If you replace the active ballast assembly, refer to Table 5-3 for active ballast assembly connections. See also Figure 8-3 in the *Wiring Schematics* section. Refer to *Active Ballast Assembly Replacement* in the Repair section.

Table 5-3 Active Ballast Assembly Connections

This connector...	Connects to this device...	Note
LA1, LA2	A string of up to eight 48 W backup lamps	A
LB1, LB2	A string of up to eight 48 W primary lamps	A
T1, T2	The output of a 6.6 A isolation transformer providing power for the sign	A
M+, M-	Optional lamps-out indicator	B
AC1, AC2, BR+, BR-	Bridge rectifier	B
MON, NO, NC	Contacts for remote lamps-out monitoring	B, C
<p>NOTE A: See Figure 5-2 for connector location on the main board of the active ballast assembly.</p> <p>NOTE B: These connectors are located on the wiring harness.</p> <p>NOTE C: Connect to MON and NO for normally open contacts. Connect to MON and NC for normally closed contacts. Contacts are rated at 48 Vdc and 100 mA. The maximum resistance is 20 ohms.</p>		

Section 6

Repair



WARNING: Allow only qualified personnel to perform the following tasks. Observe and follow the safety instructions in this document and all other related documentation.

1. Introduction

This section provides procedures for replacing lamps and active ballast assembly.

2. Halogen Lamp Replacement

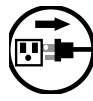

WARNING: Turn off the power to the sign before replacing lamps. Failure to observe this warning may result in personal injury, death, or equipment damage.

To replace lamp(s), perform the following procedure:

1. Turn off the power to the sign.
2. See Figure 6-1. Remove the lamp cover (1) by rotating the lamp cover (1) counterclockwise.

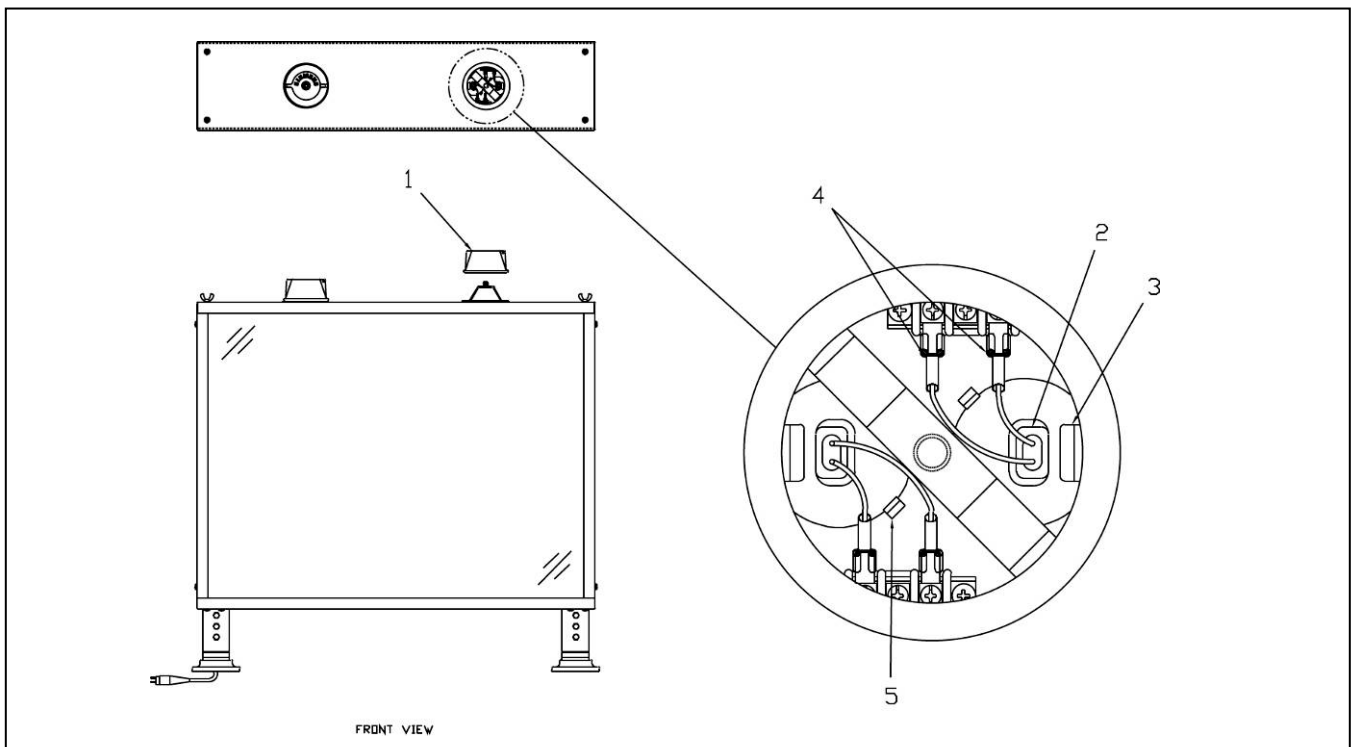

Figure 6-1 Halogen Lamp Replacement (Shown with Backup Lamp)

- | | | |
|---------------|--------------------------|-----------------------|
| 1. Lamp Cover | 3. Lamp Retention Spring | 5. Lamp Retention Tab |
| 2. Lamp | 4. Lamp Leads | |

2. Lamp Replacement (*cont*)

3. Disconnect lamp leads (4).

Note: The back-up lamp is identified by either a **"B"** or the words **"Back-up Lamp"** stamped next to the terminal block for the back-up lamp. See photographs below.

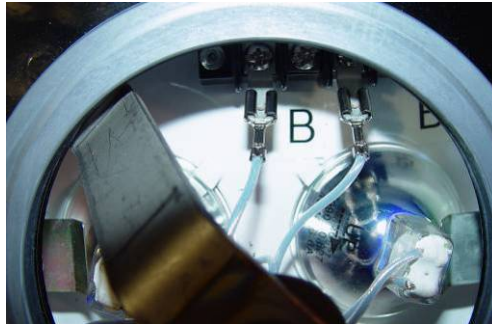

4. Remove lamp(s) by sliding lamp toward lamp retention spring (3) and rotating past lamp retention tabs (5).
5. Install replacement lamps by reversing the removal process.

NOTE: Disregard lamp orientation arrow and associated note on the lamp. This note DOES NOT apply to signature series signs.

See Figure 6-1. Replace the lamp cover (1) by rotating the lamp cover (1) clockwise until finger-tight, then turn one-half turn further to insure a watertight seal. Replace the gasket if worn or damaged.

3. Halogen Active Ballast Assembly Replacement – 48W/MR16

Styles 2 and 3 use the same active ballast assembly.

Note: There are two different active ballasts used with the halogen lamps. Active ballast 44A6225 is used in the sign assembly when there is a max of 8 lamps. Active ballast 44A6225-4 is used in the sign assembly when the max number of lamps is 4. An identification label is attached to active ballast assembly and can be seen once the sign lid is removed. If label is not on the active ballast assembly, verify the number of lamps in the sign before ordering replacement active ballast assembly.

To replace the active ballast assembly, perform the following procedure:

1. See Figure 6-2. Remove the mounting screws (2).

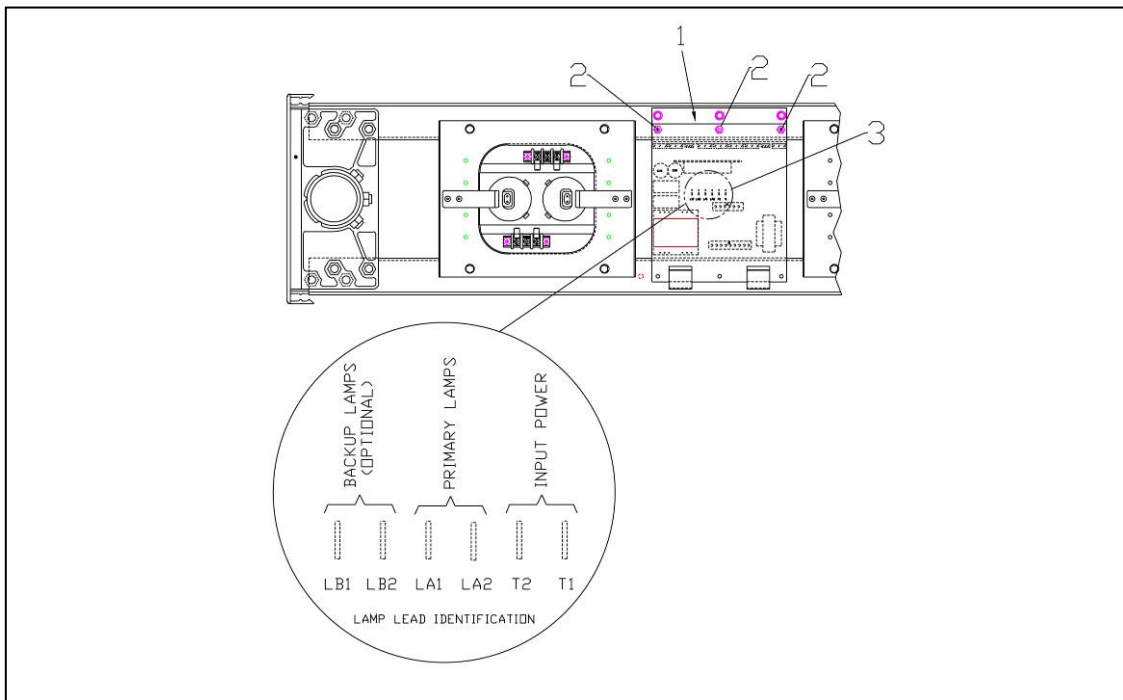

Figure 6-2 Replacing Active Ballast Assembly -48W/MR 16 Lamps

1. Active Ballast Assembly (See Note above)
2. 8–32 Self-Taping Screws
3. Lamp Leads
4. Remove the active ballast assembly (1). See Note above.
5. Disconnect the L-823 cord set and disconnect the lamp leads (3). Remove the Bridge Rectifier wires. See Fig. 8-5.
6. Reverse steps 1 through 4 to install the new active ballast assembly.

4. Optional Fluorescent Lamp, Ballast, and Power Supply Replacement

1. To service any of the electronic components or lamps the sign lid must be removed. (Note: If lid has lamp covers on the top of the lid, the fluorescent lamps are not accessible through these covers). Follow the directions below to remove and replace the lamp. Also, if the ballast, DC power supply, or the power transformer needs to be serviced, the legend panel located on the power cord end must be removed.
2. For size 1, 2, 3, and 5 signs, remove and replace the lamp by turning the ¼-turn screw counter clockwise to free the lamp bracket. Lift the lamp bracket and wire harness up through opening in the bracket mounting plate.

For size 4 signs, slide one of the sign legend panels up and out of the sign to access the lamps.

Note:

The lamps may have cable ties used to hold the lamps in place during shipping. Remove these cable ties prior to lamp replacement. These cable ties do not need to be replaced.

Remove the lamp from its socket by grasping the base of the lamp and lifting the lamp up and rocking it slightly left and right while lifting to free it from the socket. Pull the lamp free from the lamp clip located near the top of the lamp. See Figures 6-3 thru 6-5.



¼-turn
Screw

Figure 6-3 Lamp Bracket ¼-turn Screw



Figure 6-4 Lamp Bracket Removal



Figure 6-5 Lamp Socket

- To replace the lamp ballast, remove the 2 mounting screws, one screw at each end of the ballast that secures the ballast to the mounting plate. Disconnect the power leads located at each end of the ballast. Replace the ballast, reconnect the wiring harness to the appropriate terminals, and remount in reverse order from removal. See Figure 6-6.

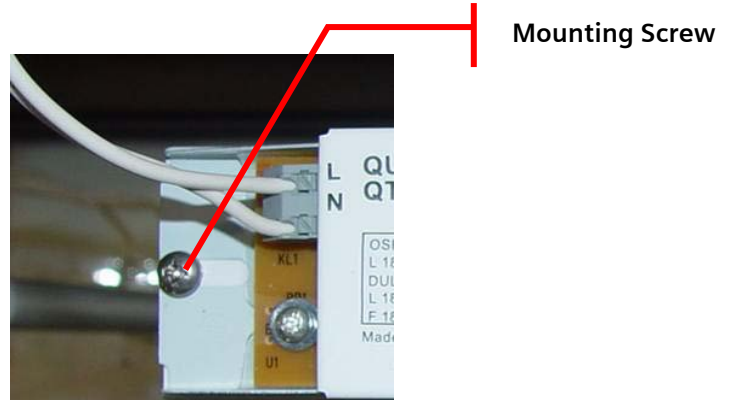
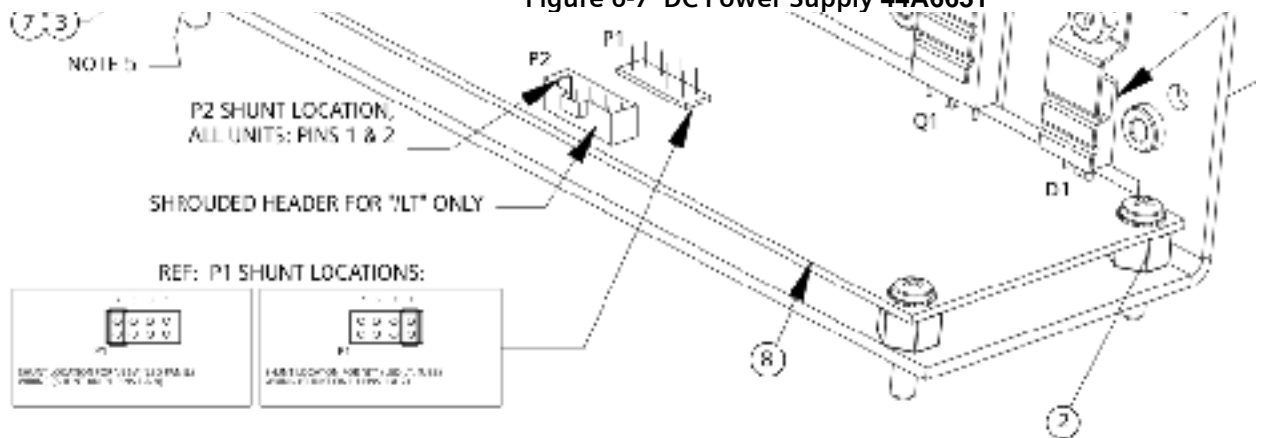

Figure 6-6 Ballast Mounting

- To replace the DC Power Supply, disconnect the 4 quick disconnects and then using a screwdriver remove the two mounting screws located on the outside surface of the sign end panel. Replace the power supply in reverse order of removal. See Figure 6-7



Figure 6-7 DC Power Supply 44A6631



P1 is empty for the Fluorescent sign and P2 has a jumper across pins 1 & 2.

4. Replacing the Fluorescent lamp ballast

If replacing the ballast with one of the following, you must also replace the power supply with a 44A6631 PCB for the first ballast replacement.

Fluorescent Ballasts

35A0543-1C	Lamp Ballast – Single (OSRAM)	1-2
35A0543C	Lamp Ballast – Dual (OSRAM)	1-4

Fluorescent Power Supply

44A6631	Fluorescent Lamp Power Supply PCB Assembly	1
---------	--	---

There are 3 versions of this power supply, 44A6631, 44A6631/96 and 44A6631/LT.

Make certain you have the 44A6631 power supply.

4. Standard VA Transformer and Capacitor Replacement

Standard VA Transformer

35A0635 Style 2/3 Step 1 to 4 lamps

35A0642 Style 3/5 Step 3 to 8 lamps

35A0644 Style 3/5 Step 1 to 2 lamps

NOTE: for some configurations the 0642 and 0644 transformers are used in combination with each other.

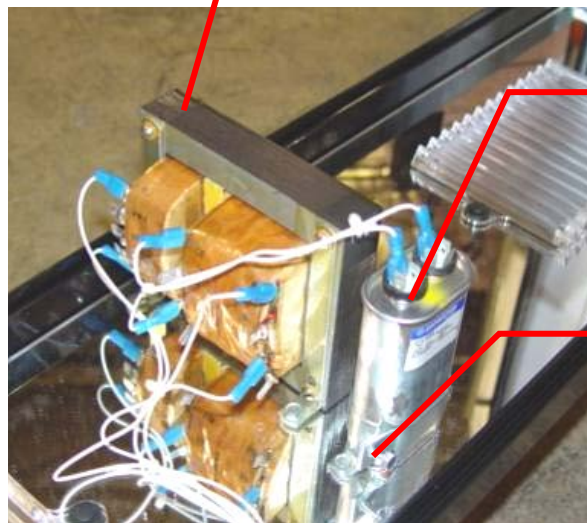

Standard VA Transformer Capacitor

20A0035 (use with 35A0644)

20A0036 (use with 35A0642)

Capacitor Clamp

61A0197

Figure 6-8 Regular VA Transformer and CAP

Section 7

Parts

1. Introduction

To order parts, call ADB Airfield Solutions Customer Service or your local ADB Airfield Solutions representative. Use this four-column parts list, and the accompanying illustration, to describe and locate parts correctly.

2. Using the Illustrated Parts List

This subsection describes how to use the illustrated parts list covered later in this section. It does not provide the actual parts list.

The Part Number column gives the ADB Airfield Solutions part number in numerical order.

The Description column gives the part name, as well as its dimensions and other characteristics when appropriate.

Part Number	Description	Quantity	Note
xxxxxxx	Assembly	1	A
xxxxxxx	Part	1	
xxxxxxx	Part or Assembly	2	
xxxxxxx	Assembly	1	
NOTE A			

The Quantity column contains the quantity required per unit, assembly, or subassembly. The code AR (As required) is used if the part number is a bulk item ordered in quantities or if the quantity per assembly depends on the product version or model.

The Note column contains letters that refer to notes at the end of each parts list. Notes contain special ordering or product/part version information.

3. L-858 Sign Ordering Code

See below Figure to determine the part number for a particular L-858 module.

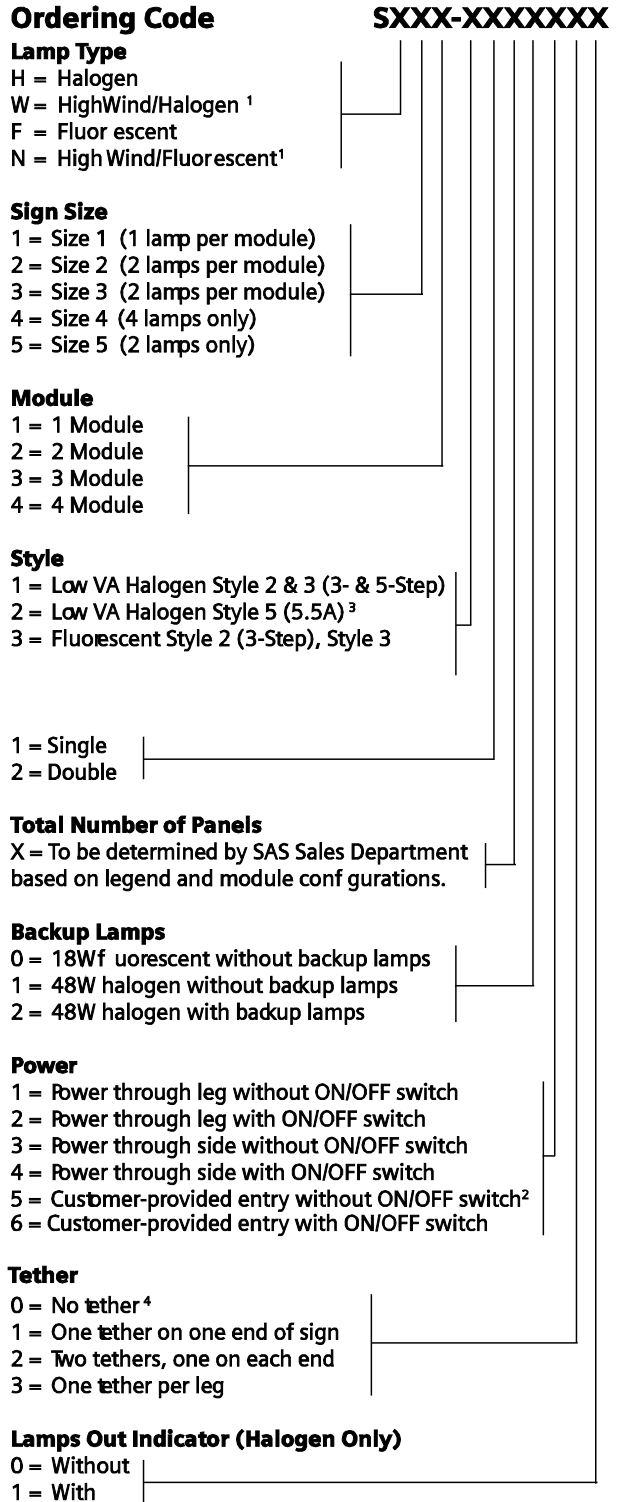

Ordering Code Notes

- Customer to provide legend information and power connection side. It is important to match power cord exit location with legend side.
- ¹ Use high wind signs in those locations where actual wind speed exceeds FAA specifications (Mode 3). High wind signs tested to a minimum wind load of 327 mph as recommended by FAA technical paper DOT/FAA/AR-TN00/32: Evaluation of Wind-Loading on Airport Signs. High wind signs require four anchor bolts per floor flange except Size 1, which uses the standard 2-bolt foot.
- ² Cord set coiled up inside side. Customer provides entry hole.
- ³ Backup lamps and lamps out features are not available.
- ⁴ Not ETL Certified.

4. L-858 Sign Parts List

See Figure 7-1.

HALOGEN SIGN ONLY			
Part Number	Description	Quantity	Note
RM0496	Latching cover seal	0-1	A
RM0497	Top lid seal	2	
20A0035	Capacitor 3 μ F, 660Vac - use with 35A0642	1	E
20A0036	Capacitor 1.5 μ , 660Vac - use with 35A0644		E
35A0455	Transformer – Standard VA, Style 5		
35A0635	Transformer – Standard VA Style 2/3 Step 1 to 4 lamps		
35A0642	Transformer – Standard VA Style 3/5 Step 1 to 4 lamps		F
35A0644	Transformer - Standard VA Style 3/5 Step 1 to 2 lamps		F
44A6527-1	Optical bracket assembly, without optional lamps	1-8	
44A6527-2	Optical bracket assembly, with optional lamps	1-8	
44A6172-1	Panel support assembly, Size 1	0-6	
44A6172-2	Panel support assembly, Size 2	0-6	
44A6172-3	Panel support assembly, Size 3 and Size 5	0-6	
44A6172-4	Panel support assembly, Size 4	0-2	
44A6173-1	Panel divider assembly, Size 1	0-6	G
44A6173-2	Panel divider assembly, Size 2	0-6	G
44A6173-3	Panel divider assembly, Size 3	0-6	G
44A6225	Active ballast assembly MAX 8 Lamps	1	D
44A6225-4	Active ballast assembly MAX 4 Lamps	1	D
44A6251-1	Sign rectifier assembly, Size 1, 2, 3, and 5	1	
44A6251-2	Sign rectifier assembly, Size 4	1	
60A2653	Lamp cover	1-8	
<p>NOTE A: Latching cover and latching cover seal are required only on signs with two-piece lids. Signs with two-piece lids include Size 1, 4-module; Sizes 2, 3- and 4- module; and Size 3, 3- and 4-module.</p> <p>NOTE B: For use on Style 5 Halogen only.</p> <p>NOTE C: Not shown on Figure 7-1.</p> <p>NOTE D: The active ballast (standard VA) assembly is used only on Style 2 and Style 3 using 48W/MR16 Halogen lamps.</p> <p>NOTE E: Only used for Regular VA Signs</p> <p>NOTE F: Requires capacitor – see parts list for required CAP</p> <p>NOTE G: Color of Panel Dividers are as follows: Location panel against any other color – divider is clear/black Mandatory/Mandatory – divider is clear/red Informational/Informational – divider is clear/yellow Blank/Blank – divider is black/black</p>			
Continued on next page			

4. L-858 Sign Parts List (*cont*)

Part Number	Description	Quantity	Note
60A2678-10	Frangible fitting, Size 1	2-5	
60A2678-20	Frangible fitting, Size 2	2-5	
60A2678-30	Frangible fitting, Size 3 and Size 5	2-5	
60A2678-40	Frangible fitting, Size 4	3	
60A2711	Latching cover	0-1	A
60A2844	Transformer mounting bracket – used w/35A0455	0-1	B
61A0333	Diffuser support spring	4-32	
61A0335-1	Flush type panel fastener	2-16	
62A2142	Mounting flange (2-bolt)	2-5	
62A2146	Mounting flange, high wind speed (4-bolt)	2-5	
63A0904	Clamp, self-adhesive	2	
63A0987	Diffuser	2-16	
63A0989	Lamp cover seal	1-8	
63A1004	Prism diffuser	1-8	
64A0953-1	Wing bolt	4-12	
72A0010	Ground lug	1-2	
73A0107-72	L-823 cord set	1	
94A0054	L-858 tether kit	0-5	C
2990.40.827	Lamp, 48 W, 6.6 A, MR16	1-16	
1832BSPLT	Base plate	0-1	C
FLUORESCENT PARTS			
48A0376	Lamp 18W OSRAM 18W/31-830SP	1- 8	
35A0543-1C	Lamp Ballast – Single (OSRAM)	1-2	
35A0543C	Lamp Ballast – Dual (OSRAM)	1-4	
60A1038-1	Lamp Bracket – Size 1	N/S	
60A1038-2	Lamp Bracket – Size 2	N/S	
60A1038-3	Lamp Bracket – Size 3	N/S	
60A2989	Lamp Support Bar –Size 4	N/S	
60A3002	Lamp Support – Size 4	1- 8	
60A3195	Ballast Mounting Bracket	1-4	
49A0357	Lamp Support Clip	1-8	
49A0356	Lamp Socket	1- 8	
44A6631	Fluorescent Lamp Power Supply PCB Assembly	1	
63A1056	Diffuser Plate- Bottom	2	
NOTE A: Latching cover and latching cover seal are required only on signs with two-piece lids. Signs with two-piece lids include Size 1, 4-module; Sizes 2, 3- and 4- module; and Size 3, 3- and 4-module.			
NOTE B: For use on Style 5 Halogen only. NOTE C: Not shown on Figure 7-1.			
NOTE D: For part numbers of individual components in the assembly contact ADB Sales Dept.			
N/S = Not Shown			

4. L-858 Sign Parts List (cont)

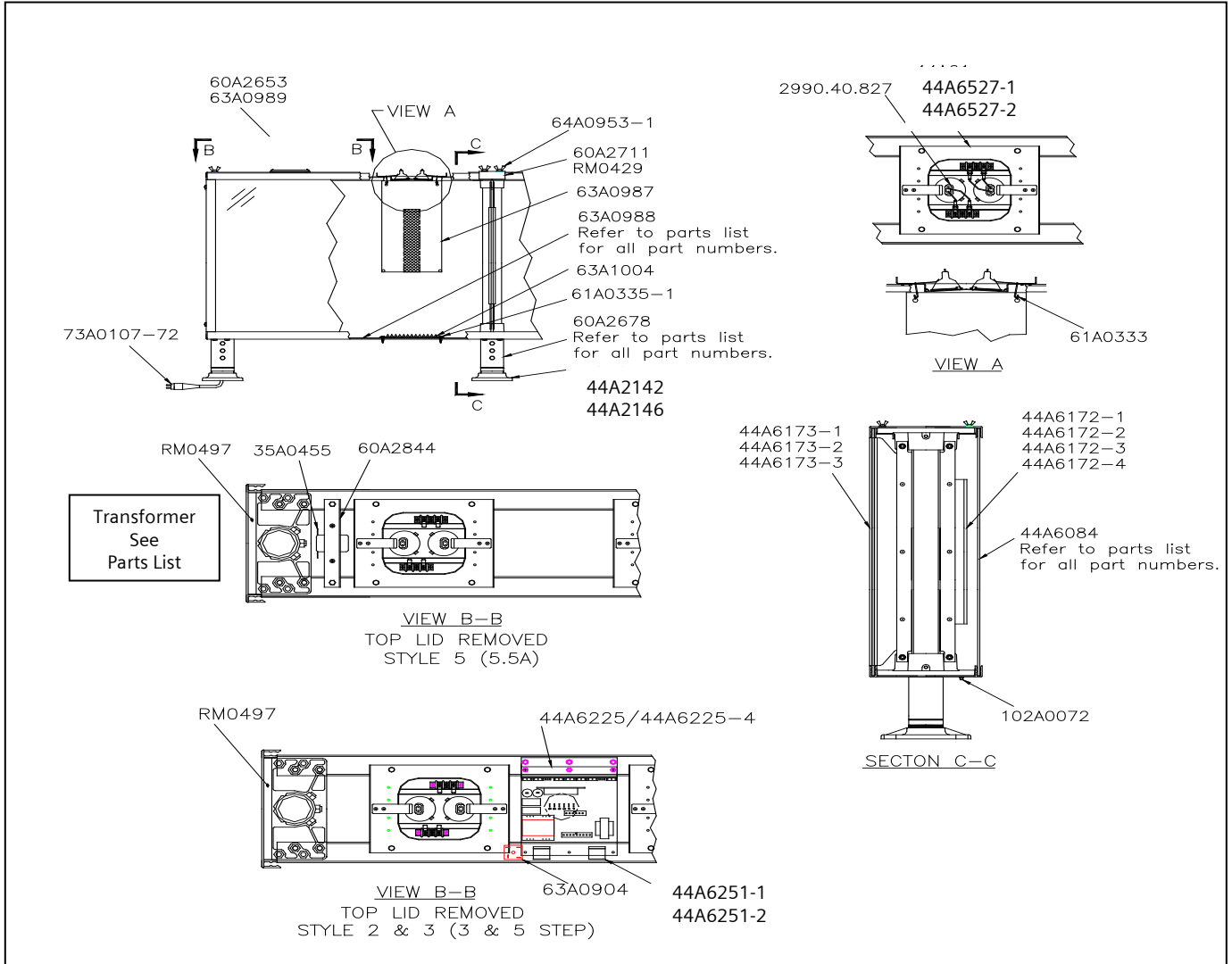

Figure 7-1 L-858 Sign Module Assembly (Shown with Backup Lamps)

5. L-858 Sign Legend Panel Assembly Parts List

This subsection provides the legend panel assembly parts list for the L-858 sign. See Figure 7-1.

Part Number	Description	Quantity	Note
44A6084-1110	Legend panel, Size 1, 1-module, retroreflective	See note.	A
44A6084-1210	Legend panel, Size 1, 2-module, retroreflective	See note.	A
44A6084-1310	Legend panel, Size 1, 3-module, retroreflective	See note.	A
44A6084-2110	Legend panel, Size 2, 1-module, retroreflective	See note.	A
44A6084-2210	Legend panel, Size 2, 2-module, retroreflective	See note.	A
44A6084-2310	Legend panel, Size 2, 3-module, retroreflective	See note.	A
44A6084-3110	Legend panel, Size 3, 1-module, retroreflective	See note.	A
44A6084-3210	Legend panel, Size 3, 2-module, retroreflective	See note.	A
44A6084-3310	Legend panel, Size 3, 3-module, retroreflective	See note.	A
44A6084-4110	Legend panel, Size 4, 1-module, retroreflective	See note.	A
44A6084-1120	Legend panel, Size 1, 1-module, black	See note.	A
44A6084-1220	Legend panel, Size 1, 2-module, black	See note.	A
44A6084-1320	Legend panel, Size 1, 3-module, black	See note.	A
44A6084-2120	Legend panel, Size 2, 1-module, black	See note.	A
44A6084-2220	Legend panel, Size 2, 2-module, black	See note.	A
44A6084-2320	Legend panel, Size 2, 3-module, black	See note.	A
44A6084-3120	Legend panel, Size 3, 1-module, black	See note.	A
44A6084-3220	Legend panel, Size 3, 2-module, black	See note.	A
44A6084-3320	Legend panel, Size 3, 3-module, black	See note.	A
44A6084-4120	Legend panel, Size 4, 1-module, black	See note.	A
60A2683-10	Panel Support Size 1 and 2 (not shown)		
60A2683 - 30	Panel Support Size 3 and 4 (not shown)		
NOTE A: Quantity per customer request.			

6. L-858 Sign Mirror Parts List

See Figure 7-1.

Part Number	Description	Quantity	Note
63A0998-11	Sign mirror, Size 1, end-end	As required	
63A0998-12	Sign mirror, Size 1, end-intermediate	As required	
63A0998-13	Sign mirror, Size 1, intermediate-intermediate	As required	
63A0998-21	Sign mirror, Size 2, end-end	As required	
63A0998-22	Sign mirror, Size 2, end-intermediate	As required	
63A0998-23	Sign mirror, Size 1, intermediate-intermediate	As required	
63A0998-31	Sign mirror, Size 3 and Size 5, end-end	As required	
63A0998-32	Sign mirror, Size 3 , end-intermediate	As required	
63A0998-33	Sign mirror, Size 3, intermediate-intermediate	As required	
63A0998-42	Sign mirror, Size 4, end-intermediate	As required	

7. Optional Lamps-Out Indicator Kit

The part number for the optional Lamps-Out Indicator Kit is 94A0373.

8. Optional On/Off Switch

The part number for the optional On/Off switch is 45A0456.

9. Recommended Spare Parts

See Figure 7-1.

NOTE: Recommended quantity is dependent upon the number of signs.

Part Number	Description	Note
RM0496	Latching cover seal	A
20A0035	Capacitor, 3 μ F, 660Vac – use with 35A0644	
20A0036	Capacitor, 1.5 μ , 6660Vac – use with 35A0642	
35A0455	Transformer – Standard VA, Style 5	B
35A0635	Transformer – Standard VA Style 2/3 Step 1 to 4 lamps	F
35A0642	Transformer – Standard VA Style 3/5 Step 1 to 4 lamps	
35A0644	Transformer - Standard VA Style 3/5 Step 1 to 2 lamps	
44A6527-1	Optical bracket assembly, without optional lamps	
44A6527-2	Optical bracket assembly, with optional lamps	
44A6172-1	Panel support assembly, Size 1	
44A6172-2	Panel support assembly, Size 2	
44A6172-3	Panel support assembly, Size 3 and Size 5	
44A6172-4	Panel support assembly, Size 4	
44A6173-1	Panel divider assembly, Size 1	G
44A6173-2	Panel divider assembly, Size 2	G
44A6173-3	Panel divider assembly, Size 3	G
44A6225	Active ballast assembly – Max 8 Lamps	D
44A6225-4	Active ballast assembly – Max 4 Lamps	D
44A6251-1	Sign rectifier assembly, Size 1, 2, 3, and 5	
44A6251-2	Sign rectifier assembly, Size 4	
44A6631	Fluorescent Sign Power Supply PCB Assembly	
60A2653	Lamp cover	
60A2678-10	Frangible fitting, Size 1	
60A2678-20	Frangible fitting, Size 2	
60A2678-30	Frangible fitting, Size 3 and Size 5	
60A2678-40	Frangible fitting, Size 4	
<p>NOTE A: Latching cover and latching cover seal are required only on signs with two-piece lids. Signs with two-piece lids include Size 1, 4-module; Sizes 2, 3- and 4- module; and Size 3, 3- and 4-module.</p> <p>NOTE B: For use on Style 5 only. NOTE C: Not shown on Figure 7-1.</p> <p>NOTE D: The active ballast assembly is used only on Style 2 and Style 3 signs using 48W/MR16 halogen lamps.</p> <p>NOTE E: Transformer & Cap ONLY used with the Regular VA Sign</p> <p>NOTE F: Transformer does not use a capacitor</p> <p>NOTE G: Color of Panel Dividers are as follows: Location panel against any other color – divider is clear/black Mandatory/Mandatory – divider is clear/red Informational/Informational – divider is clear/yellow Blank/Blank – divider is black/black</p>		
Continued on next page		

7. Recommended Spare Parts (cont)

Part Number	Description	Note
60A2711	Latching cover	A
60A2844	Transformer mounting bracket – used with 35A0455	B
60A2953	Fluorescent Sign Optical Bracket	
61A0333	Diffuser support spring	
61A0335-1	Flush type panel fastener	
62A2142	Mounting flange (2-bolt)	
62A2146	Mounting flange, high wind speed (4-bolt)	
63A0904	Clamp, self-adhesive	2
63A0987	Diffuser	
63A0989	Lamp cover seal	
63A1004	Prism diffuser	
63A1038-X	Fluorescent Sign, Size 1 thru 3, Lamp Holder	
63A1039	Fluorescent Sign, Diffuser, Panel Retainer	
63A1042-X	Fluorescent Sign, Size 1 thru 3, Diffuser Panel	
63A1056-XX	Fluorescent Sign, Size 1 thru 3, Bottom Diffuser Panel	
64A0953-1	Wing bolt	
72A0010	Ground lug	
73A0107-72	L-823 cord set	
94A0054	L-858 tether assembly kit	C
2990.40.827	Lamp, 48 W, 6.6 A, MR16	
1832BSPLT	Base plate	C

NOTE A: Latching cover and latching cover seal are required only on signs with two-piece lids. Signs with two-piece lids include Size 1, 4-module; Sizes 2, 3- and 4- module; and Size 3, 3- and 4-module.

NOTE B: For use on Style 5 Halogen only. The internal transformer must be ordered separately.

NOTE C: Not shown on Figure 7-1. Ordered as separate part

Section 8

Wiring Schematics

1. Introduction

This section provides wiring schematics for the L-858 taxiway and runway signs.

2. Wiring Schematics

This subsection provides wiring schematics for 48W/MR16 halogen lamps as follows: Style 2, Style 3, and Style 5 signs, see Figure 8-1 for Style 5 wiring (Sizes 1, 3, 4, and 5), Figure 8-2 for Style 5 wiring (Size 2) and Figure 8-3 for the Style 2 and Style 3 wiring (all sizes and modules). For fluorescent wiring diagrams see drawing 43A2917 page 8-4 for Style 2, 3, and 5 for 2 thru 8 lamps and 43A2917 page 8-5 for Style 3, 6 or 8 lamps only.

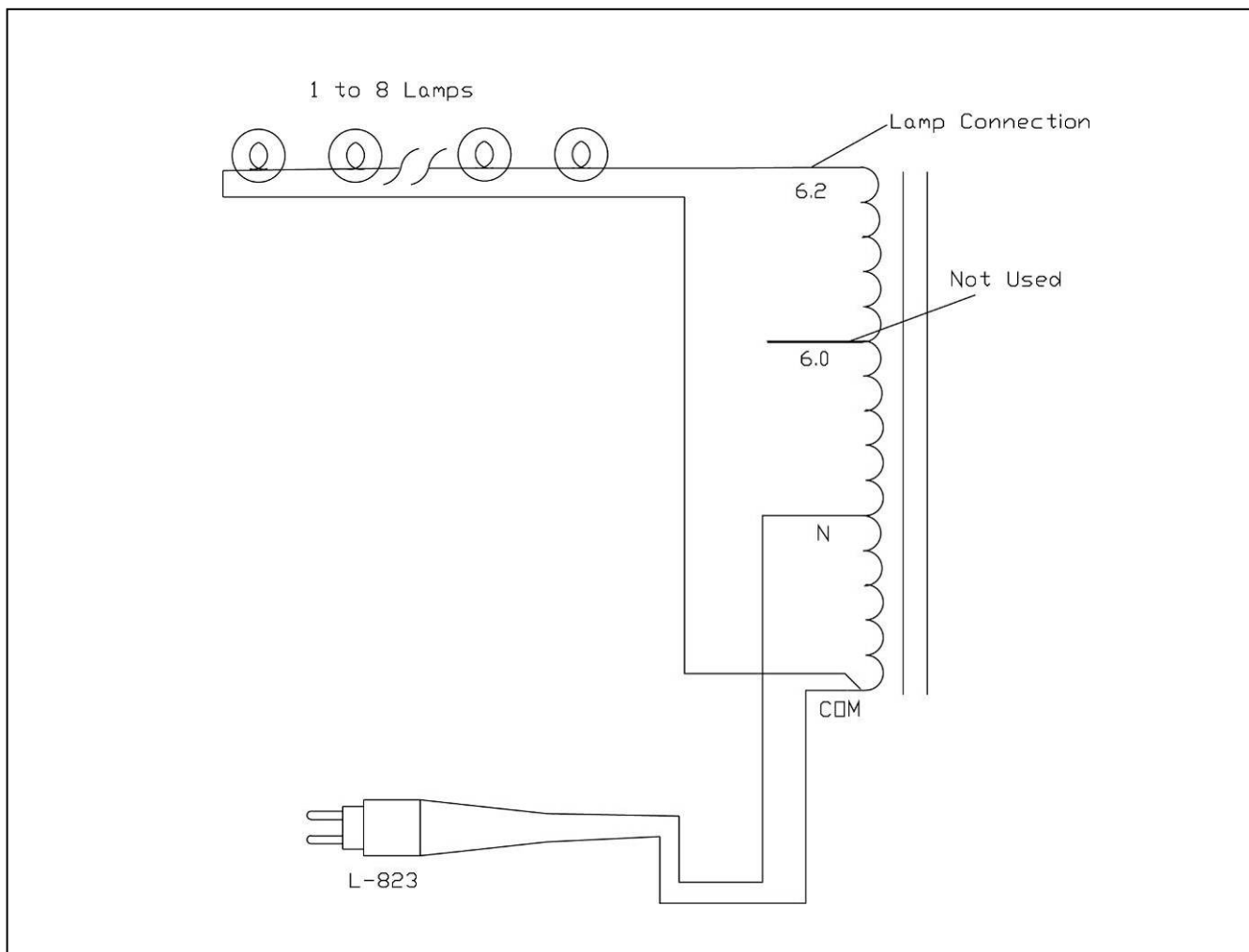

Figure 8-1 Style 5 Wiring Schematic – 48W/MR16 Lamps (Sizes 1, 3, 4, 5)

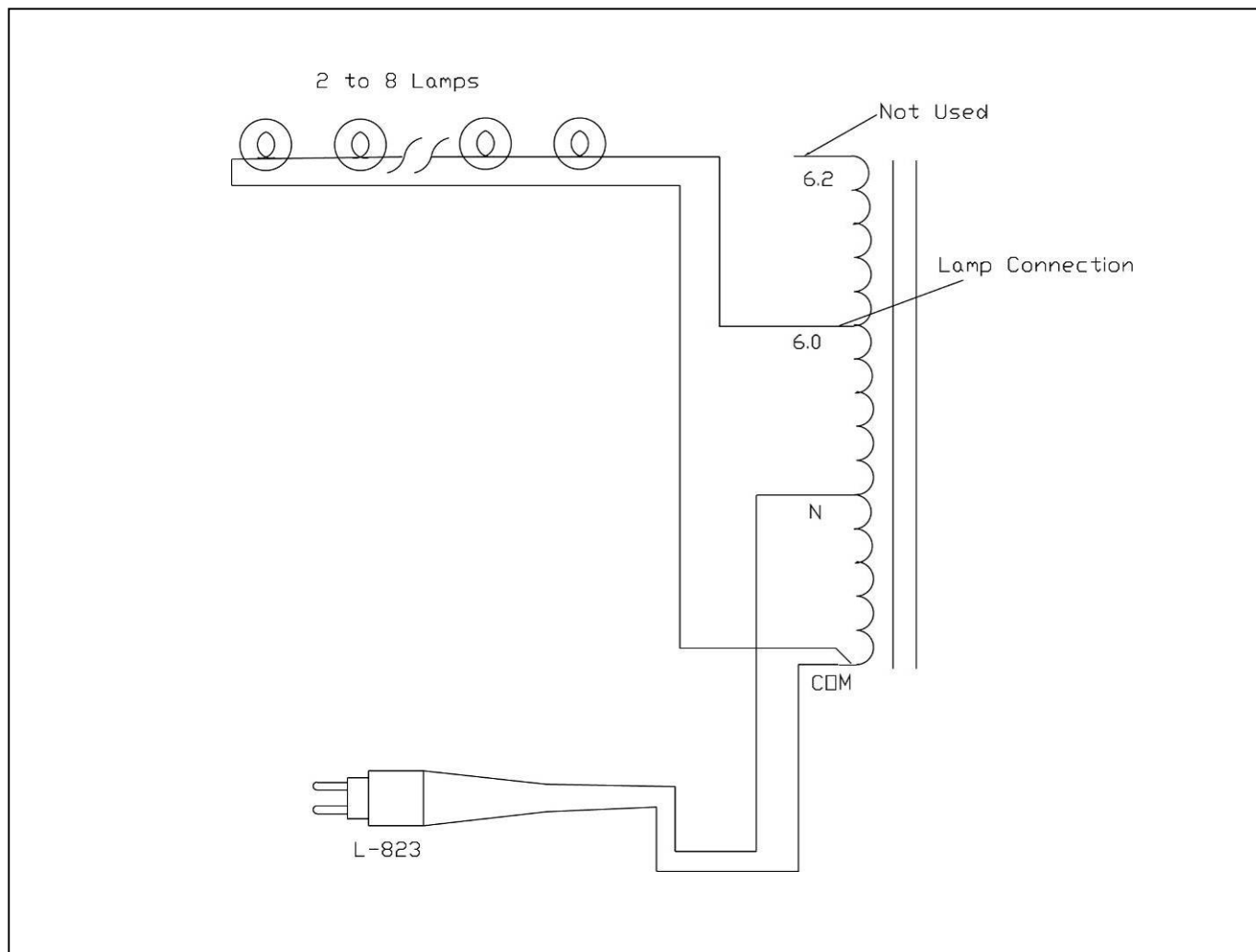

Figure 8-2 Style 5 Wiring Schematic- 48W/MR16 Lamps (Size 2)

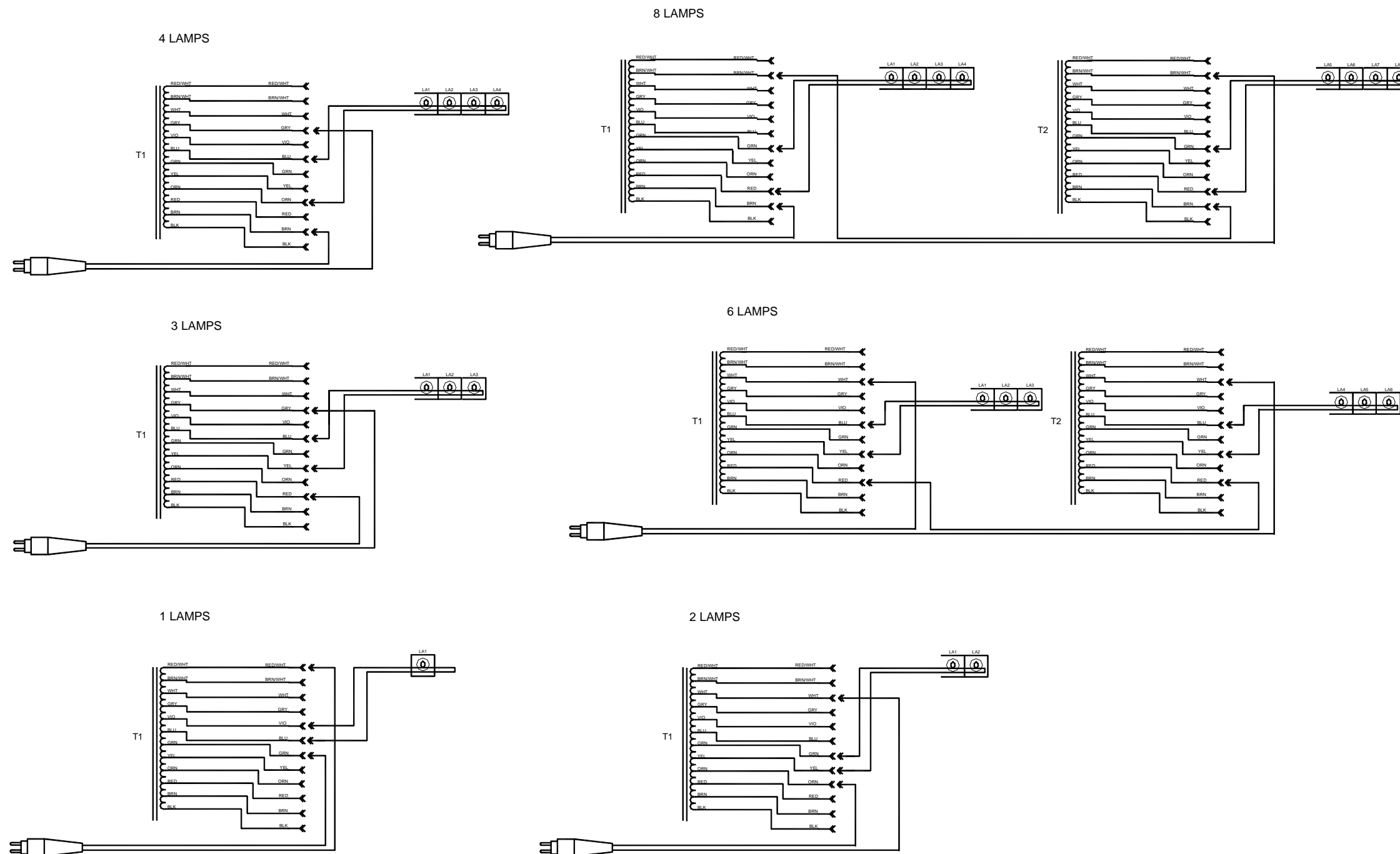

Figure 8-3 WIRING DIAGRAM, 3 STEP STANDARD VA

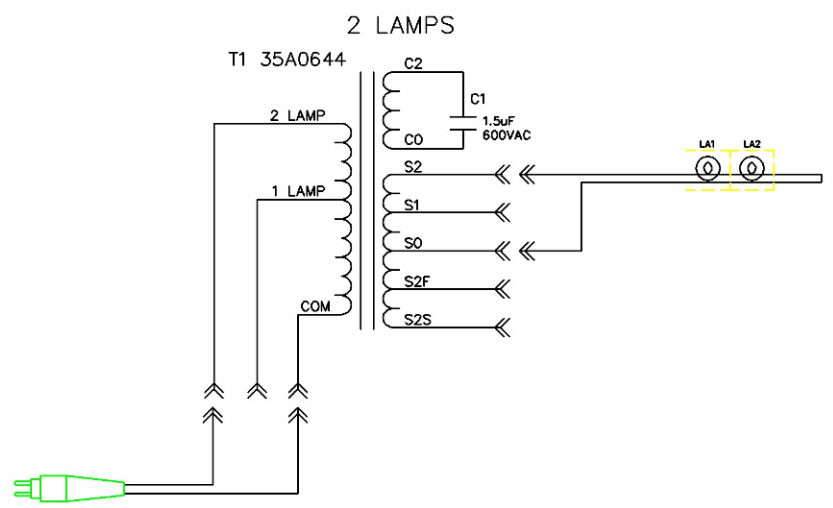
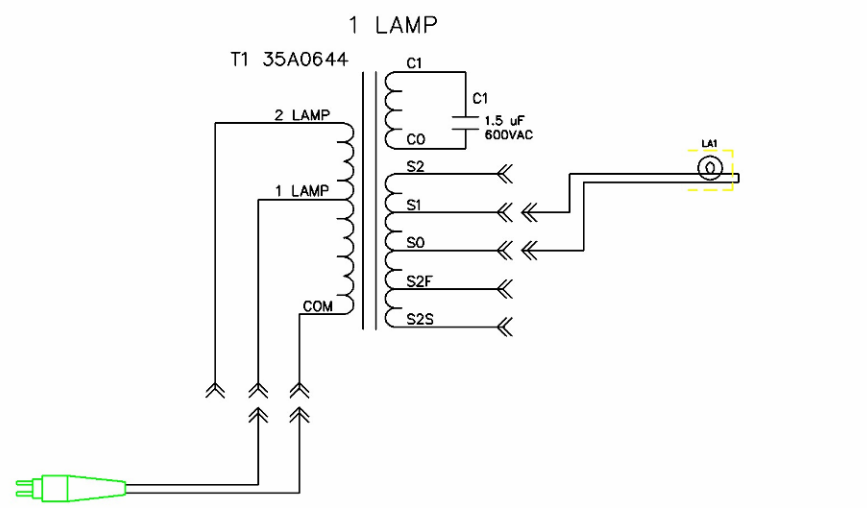
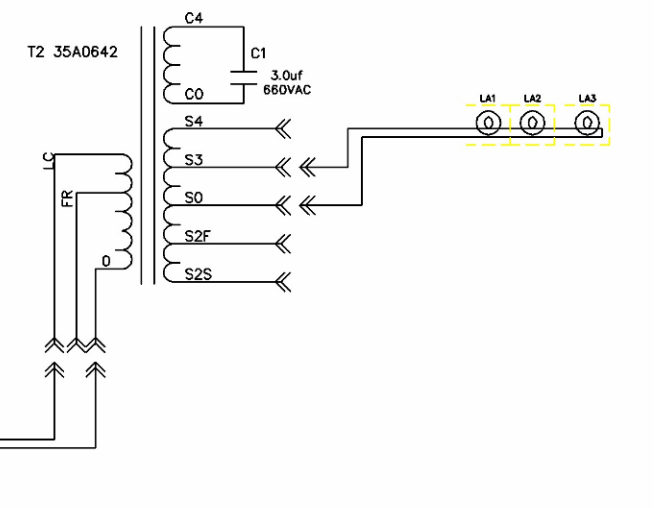
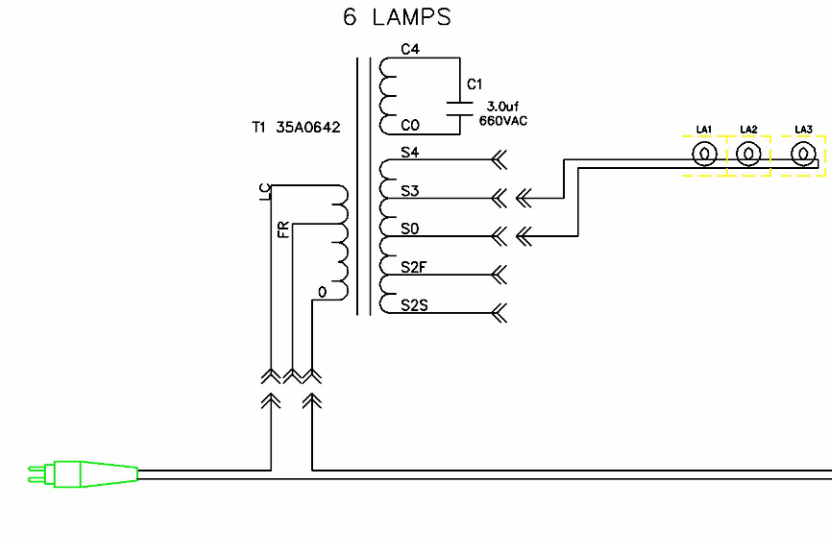
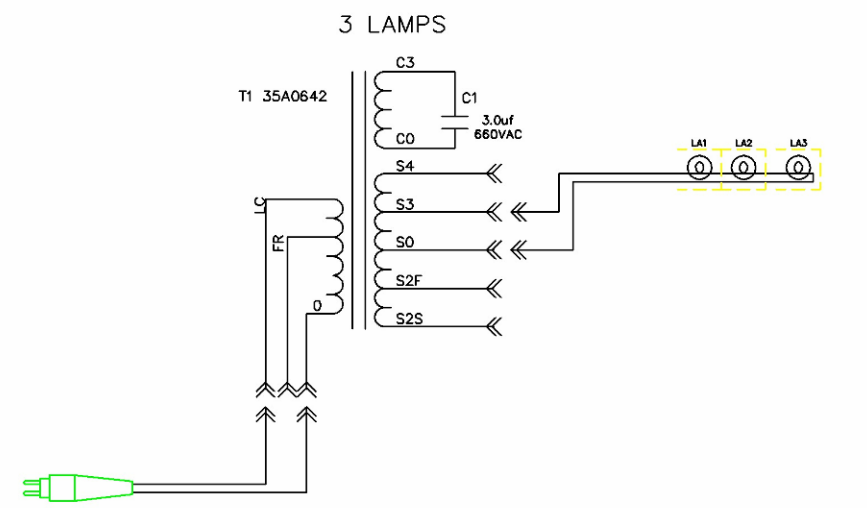
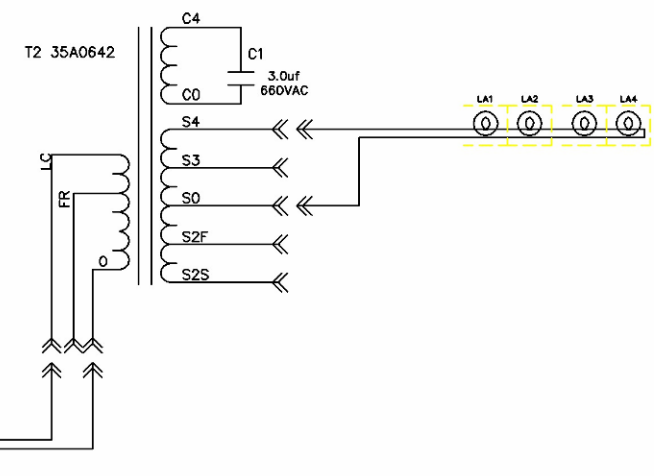
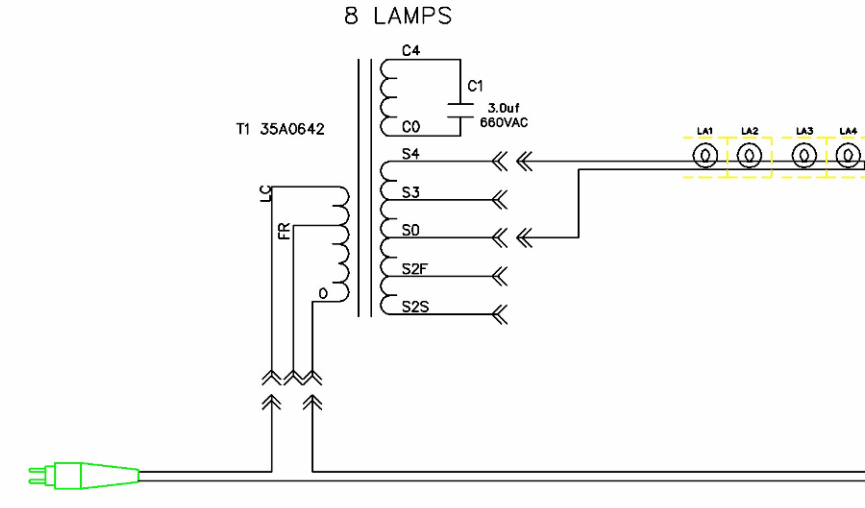
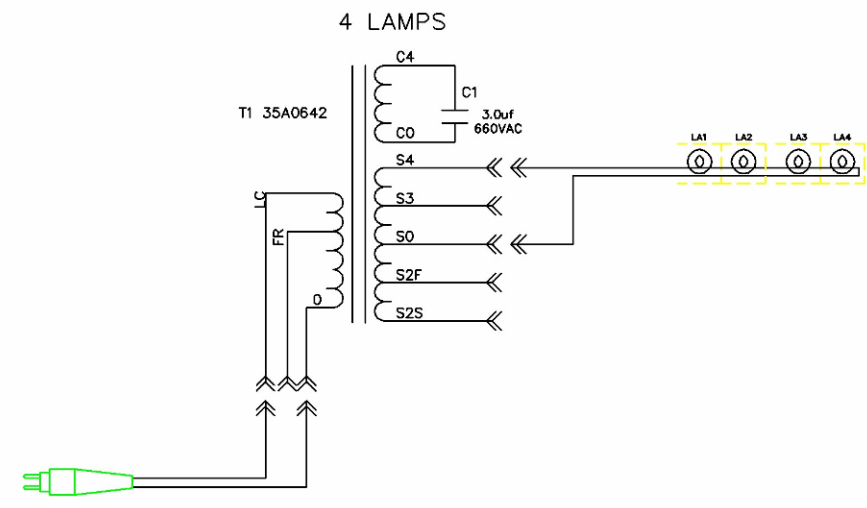

Figure 8-4 WIRING DIAGRAM, 5 STEP STANDARD VA

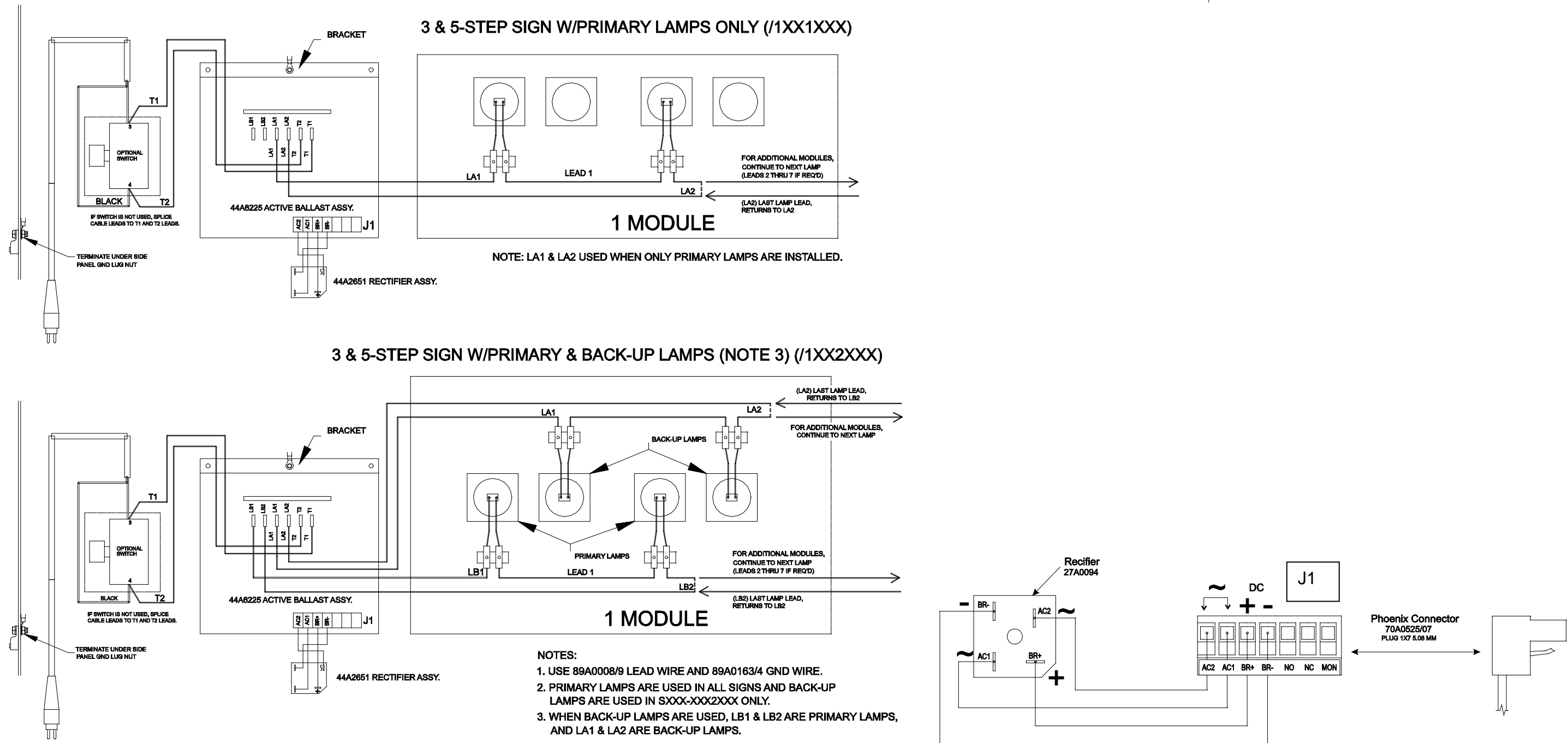
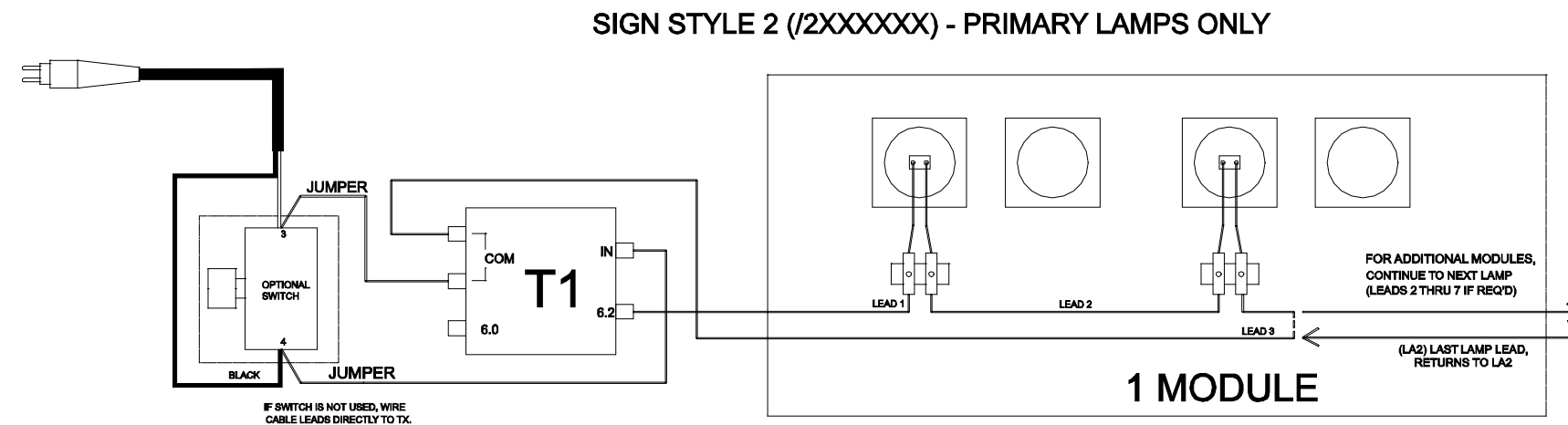

Figure 8-5 L-858 Wiring Schematic (Styles 2 and 3 / All Sizes and All Modules - 48W/MR16 Lamps)



**SIGNATURE SIGN, LAMPS
OUT LED FLASHER OPTION:**

SEE 94A0373 LAMPS OUT FLASHER
KIT, PG. 2 FOR WIRING DIAGRAM.

NOTES:

1. USE (89A0008/9) 16 AWG, 600V WIRE.
2. PRIMARY LAMPS ONLY - BACKUP LAMPS USED ONLY IN "/1XXXXXX" VERSION.

Figure 8-6 L-858 Wiring Schematic (Styles 2 / All Sizes and All Modules - 48W/MR16 Lamps)

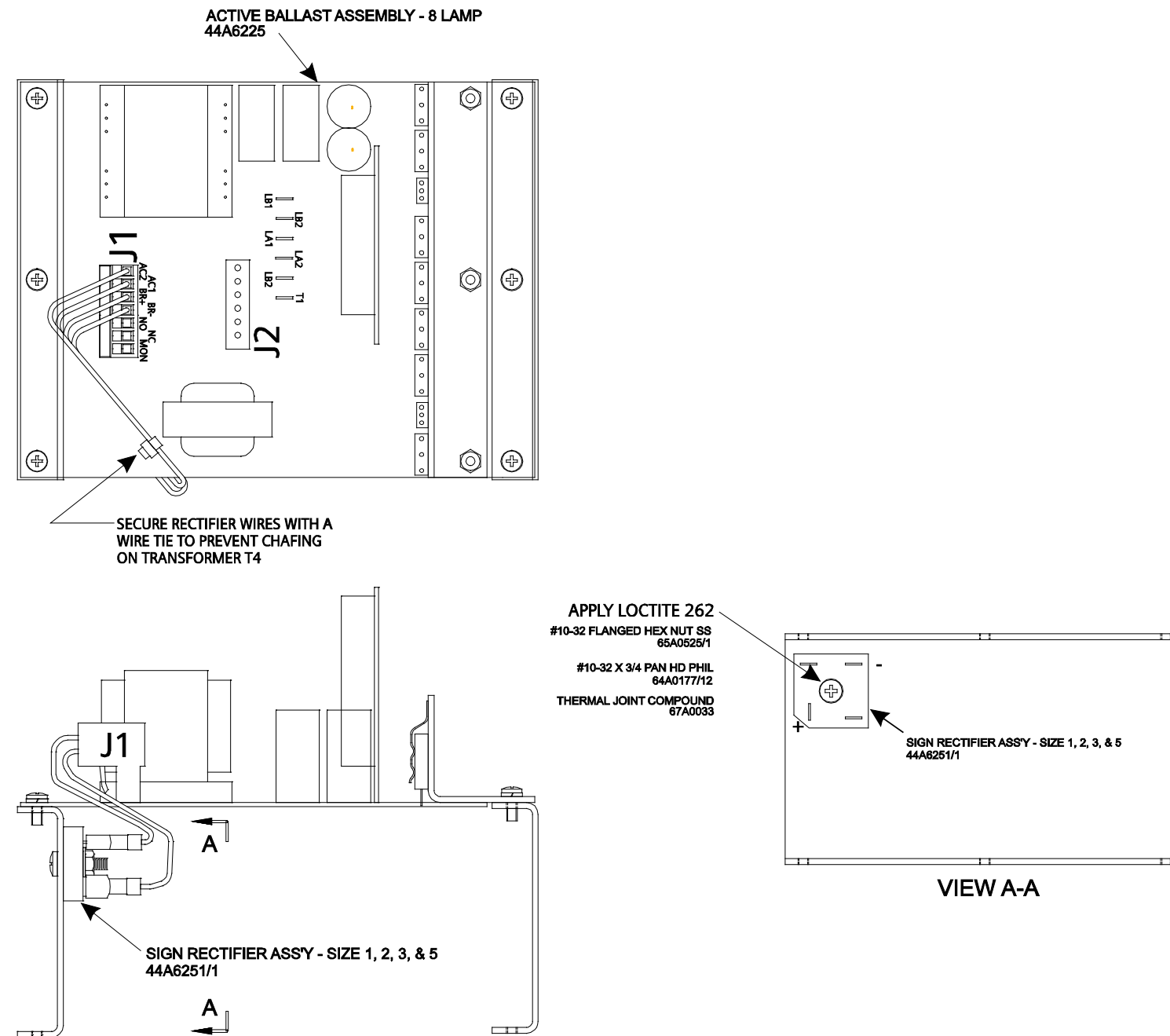

Figure 8-7 L-858 Wiring Schematic (Styles 2 and 3 / All Sizes and All Modules -48W/MR16 Lamps)

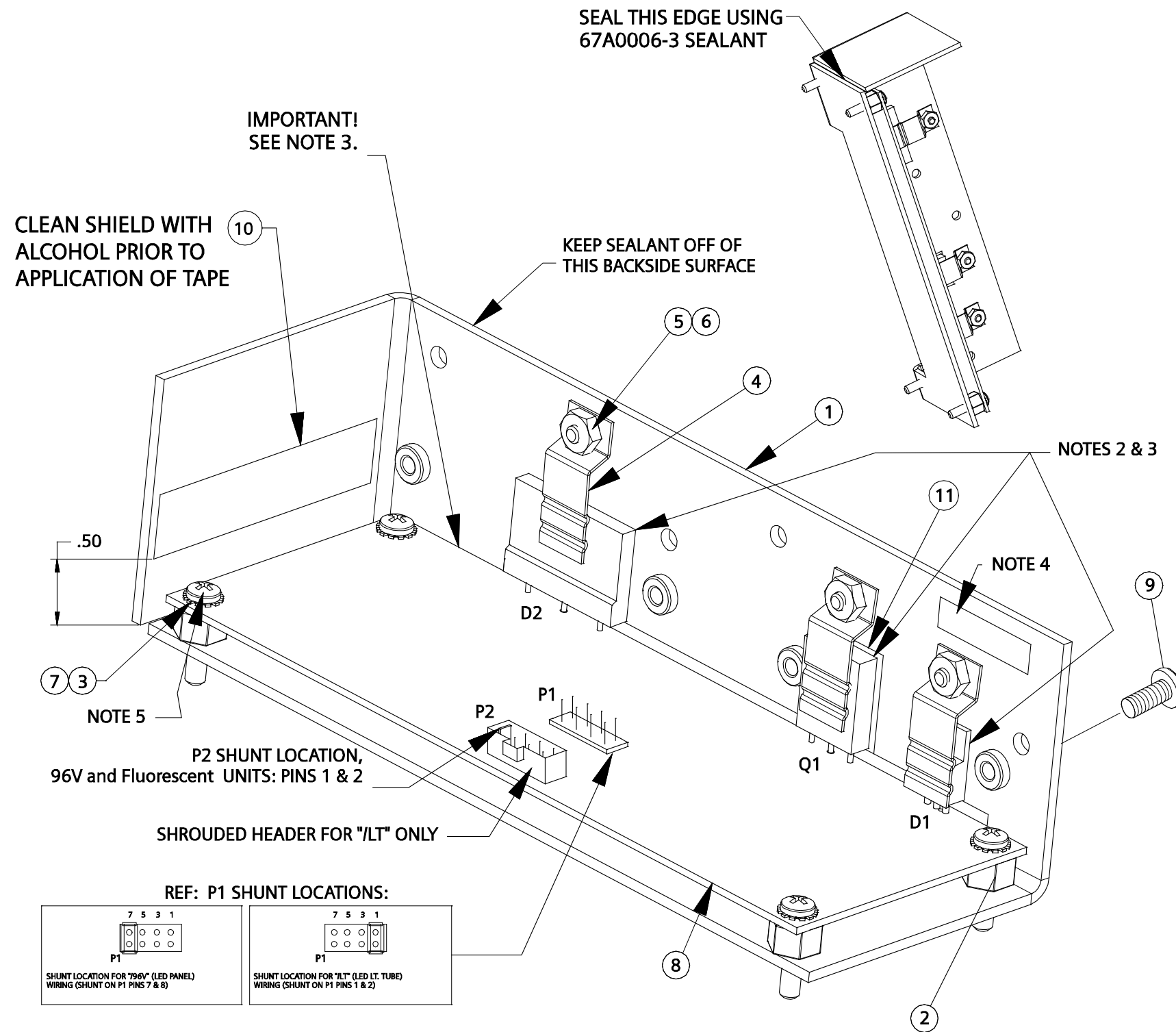

Figure 8-9 Power Supply Diagram for 1-8 Lamp Florescent Signs – 44A6631